

**Quality control methods for medicinal  
plant materials  
World Health Organization Geneva**

The World Health Organization was established in 1948 as a specialized agency of the United Nations serving as the directing and coordinating authority for international health matters and public health. One of WHO's constitutional functions is to provide objective and reliable information and advice in the field of human health, a responsibility that it fulfils in part through its extensive programme of publications.

The Organization seeks through its publications to support national health strategies and address the most pressing public health concerns of populations around the world. To respond to the needs of Member States at all levels of development, WHO publishes practical manuals, handbooks and training material for specific categories of health workers; internationally applicable guidelines and standards; reviews and analyses of health policies, programmes and research; and state-of-the-art consensus reports that offer technical advice and recommendations for decision-makers. These books are closely tied to the Organization's priority activities, encompassing disease prevention and control, the development of equitable health systems based on primary health care, and health promotion for individuals and communities. Progress towards better health for all also demands the global dissemination and exchange of information that draws on the knowledge and experience of all WHO's Member countries and the collaboration of world leaders in public health and the biomedical sciences.

To ensure the widest possible availability of authoritative information and guidance on health matters, WHO secures the broad international distribution of its publications and encourages their translation and adaptation. By helping to promote and protect health and prevent and control disease throughout the world, WHO's books contribute to achieving the Organization's principal objective - the attainment by all people of the highest possible level of health.

Cover photograph courtesy of  
Conservatoire et Jardin botaniques de la Ville de Genève

## WHO Library Cataloguing in Publication Data

Quality control methods for medicinal plant materials.

1.Plants, Medicinal 2.Medicine, Herbal  
3.Quality control - methods 4.Manuals

ISBN 92 4 154510 0 (NLM Classification: QV 766)

The World Health Organization welcomes requests for permission to reproduce or translate its publications, in part or in full. Applications and enquiries should be addressed to the Office of Publications, World Health Organization, Geneva, Switzerland, which will be glad to provide the latest information on any changes made to the text, plans for new editions, and reprints and translations already available.

© World Health Organization 1998

Publications of the World Health Organization enjoy copyright protection in accordance with the provisions of Protocol 2 of the Universal Copyright Convention. All rights reserved.

The designations employed and the presentation of the material in this publication do not imply the expression of any opinion whatsoever on the part of the Secretariat of the World Health Organization concerning the legal status of any country, territory, city or area or of its authorities, or concerning the delimitation of its frontiers or boundaries.

The mention of specific companies or of certain manufacturers' products does not imply that they are endorsed or recommended by the World Health Organization in preference to others of a similar nature that are not mentioned. Errors and omissions excepted, the names of proprietary products are distinguished by initial capital letters.

TYPESET IN HONG KONG  
PRINTED IN ENGLAND  
95/10628-Best-set/Clays-6000

# Contents

Preface

1. General notices
  2. Powder fineness and sieve size
  3. General advice on sampling
  4. Determination of foreign matter
  5. Macroscopic and microscopic examination
  6. Thin-layer chromatography
  7. Determination of ash
  8. Determination of extractable matter
  9. Determination of water and volatile matter
  10. Determination of volatile oils
  11. Determination of bitterness value
  12. Determination of haemolytic activity
  13. Determination of tannins
  14. Determination of swelling index
  15. Determination of foaming index
  16. Determination of pesticide residues
  17. Determination of arsenic and heavy metals
  18. Determination of microorganisms
  19. Radioactive contamination
  20. Culture media and strains of microorganisms
  21. Specifications for adsorbents for use in thin-layer chromatography
  22. Reagents and solutions
- Acknowledgements
- References
- Bibliography

## Preface

Plant materials are used throughout developed and developing countries as home remedies, over-the-counter drug products and raw materials for the pharmaceutical industry, and represent a substantial proportion of the global drug market. It is therefore essential to establish internationally recognized guidelines for assessing their quality. The World Health Assembly - in resolutions WHA31.33 (1978), WHA40.33 (1987) and WHA42.43 (1989) - has emphasized the need to ensure the quality of medicinal plant products by using modern control techniques and applying suitable standards. This manual describes a series of tests for assessing the quality of medicinal plant materials. The tests are designed primarily for use in national drug quality control laboratories in developing countries, and complement those described in 'The international pharmacopoeia,' which provides quality specifications only for the few plant materials that are included in the WHO Model List of Essential Drugs.<sup>1</sup> This manual does not constitute a herbal pharmacopoeia, but a collection of test procedures to support the development of national standards based on local market conditions, with due regard to existing national legislation and national and regional norms. Publications containing relevant specifications and standards, including those related to the food industry, are listed in the References and Bibliography.

The test methods described here are the best methods currently available. The manual will be revised as needed to incorporate improvements and additional tests and to reflect developments in work being carried out at national and regional levels, including projects aimed at finding replacements for toxic reagents.

In addition to the test methods, some suggestions regarding general limits for contaminants are included. They should be considered as a basis for establishing national limits. WHO is not currently able to recommend limits for contaminants since these are too diverse and there is a lack of consensus. For instance, the draft proposal for limits for some pesticides published in *Pharmeuropa*, 1993, 5(1): 19, is far more restrictive than that proposed here.

The test procedures cannot take account of all possible impurities. Common sense and good pharmaceutical practice should be applied in deciding whether an unusual substance not detectable by the prescribed tests can be tolerated.

<sup>1</sup> The international pharmacopoeia, 3rd ed. Geneva, World Health Organization. Vol. 1: General methods of analysis, 1979. Vol. 2: Quality specifications, 1981. Vol. 3: Quality specifications, 1988. Vol. 4: Tests, methods, and general requirements. Quality specifications for pharmaceutical substances, excipients, and dosage forms, 1994. The use of essential drugs. Eighth report of the WHO Expert Committee. Geneva, World Health Organization, in press (WHO Technical Report Series).

The analysis of medicinal plant materials is not restricted to those methods discussed or recommended here and many techniques similar to those used for the analysis of synthetic drugs are also frequently employed (e.g. volumetric analysis, gravimetric determinations, gas chromatography, column chromatography, high-performance liquid chromatography and spectrophotometric methods). Details of all these methods can be found in The international pharmacopoeia.

## 1. General notices

### General considerations

The metric system is used throughout the text. All temperatures are expressed in degrees Celsius (°C).

Tests are normally carried out at room temperature (between 15 and 25°C, or up to 30°C in some climatic zones), unless otherwise indicated.

Any glassware used in the tests should be of suitable quality. Graduated and volumetric vessels should be calibrated at room temperature.

When a water-bath is referred to in the text, a bath containing boiling water (about 100°C) is to be used, unless a specific water temperature is given.

Unless otherwise specified, all solutions indicated in the tests are prepared with distilled or demineralized water of adequate purity.

### Reagents and solutions

Reagents and solutions used must conform to the requirements specified in section 22 "Reagents and solutions", and are designated as follows: reagent, R; test solution, TS; volumetric solution, VS.

### Precision of measurement

#### *Quantities and volumes*

The quantities and volumes of the materials and reagents used in the tests must be measured with adequate precision, which is indicated in the following way:

A value of: 20.0 means not less than 19.5 and not more than 20.5  
2.0 means not less than 1.95 and not more than 2.05  
0.20 means not less than 0.195 and not more than 0.205.

#### *Temperature*

Temperature measurement is indicated in a manner similar to that given for quantities and volumes.

Storage conditions given in general terms refer to the following equivalent temperatures:

In a refrigerator 0-6 °C  
Cold or cool 6-15 °C  
Room temperature 15-25 °C,  
or up to 30°C depending on climatic zones.

### *pH values*

Precision in the measurement of pH values is indicated in a manner similar to that for quantities and volumes.

### **Calculation of results**

The results of tests and assays should be calculated to one decimal place more than indicated in the requirement and then rounded up or down as follows:

- if the last figure calculated is 5 to 9, the preceding figure is increased by 1;
- if the last figure calculated is 4 or less, the preceding figure is left unchanged.

Other calculations, for example in the standardization of volumetric solutions, should be carried out in a similar manner.

In the determination of ashes, extractable material, bitterness, haemolytic activities, tanninoids and swelling index and in chemical assays, calculations must be made with reference to the undried sample.

If the material has to be dried before it can be reduced to a powder for use in a determination, a correction must be made to take into account the loss on drying, and the amount of active principle calculated with reference to the undried sample.

### **Establishment of limits**

Reasonable limits may be established using simple statistical methods, e.g. control chart techniques (1,2). Analytical results from about 20 successive batches are pooled together, and the grand average and "three sigma limits" ( $\pm 3$  standard deviations from the grand average) are calculated. (Such calculations are applicable when more than one individual or independent sample per batch is analysed (3,4)).

### **Solubility**

Unless otherwise specified in the test procedure for the plant material concerned, the approximate solubility of medicinal plant materials should be determined at 20°C. Solubility is expressed in terms of "parts", representing the number of millilitres (ml) of the solvent, in which 1 g of the solid is soluble. Descriptive terms are sometimes used to indicate the solubility of a substance, with the following meanings:

very soluble	less than 1 part
freely soluble	1-10 parts
soluble	10-30 parts
sparingly soluble	30-100 parts
slightly soluble	100-1000 parts
very slightly soluble	1000-10 000 parts
practically insoluble	more than 10000 parts



## **Storage**

Medicinal plant materials must be stored under specified conditions in order to avoid contamination and deterioration.

### *Containers*

The container and its closure must not interact physically or chemically with the material within in any way that would alter its quality. The following descriptive terms are used to indicate general requirements for the permeability of containers:

*A well-closed container* must protect the contents from extraneous matter or from loss of the material under normal conditions of handling, shipment, or storage.

*A tightly closed container* must protect the contents from extraneous matter, from loss of the material, and from efflorescence, deliquescence, or evaporation under normal conditions of handling, shipment, or storage. If the container is intended to be opened on several occasions, it must be designed to be airtight after reclosure.

### *Protection from light*

Medicinal plant materials requiring protection from light should be kept in a light-resistant container that - either by reason of the inherent properties of the material from which it is made or because a special coating has been applied to it - shields the contents from the effects of light. Alternatively, the container may be placed inside a suitable light-resistant (opaque) covering and/or stored in a dark place.

### *Temperature*

Materials that need to be stored at temperatures other than room temperature should be labelled accordingly.

### *Humidity*

Low humidity may be maintained, if necessary, by the use of a desiccant in the container provided that direct contact with the product is avoided. Care must be taken when the container is opened in damp or humid conditions.

## **Size of cut**

Medicinal plant materials are used either whole, or in cut or powdered form.

Cut medicinal plant materials are prepared by cutting or crushing the plant into small pieces. The cut is graded according to the aperture size of the mesh of the sieve through which the material will pass, and is indicated as follows:

	<i>Aperture size (mm)</i>
coarse cut	4.00
medium cut	2.80
fine cut	2.00

Powders are discussed in section 2.

**Units of measurement**

The names and symbols for units of measurement used in this manual conform with those used in *The international pharmacopoeia* (5) and those of the International System of units (SI), developed by the General Conference of Weights and Measures (CGPM) in collaboration with other international organizations (6,7).

## 2. Powder fineness and sieve size

### Powders

The coarseness or fineness of a powder is classed according to the nominal aperture size expressed in hum of the mesh of the sieve through which the powder will pass, and is indicated as follows:

<i>Descriptive term</i>	<i>Particle size</i>
Coarse (2000/355)	All the particles will pass through a No. 2000 sieve, and not more than 40% through a No. 355 sieve
Moderately coarse (710/250)	All the particles will pass through a No. 710 sieve, and not more than 40% through a No. 250 sieve
Moderately fine (355/180)	All the particles will pass through a No. 355 sieve, and not more than 40% through a No. 180 sieve
Fine (180)	All the particles will pass through a No. 180 sieve
Very fine (125)	All the particles will pass through a No. 125 sieve

### Sieves

The wire sieves used to sift powdered medicinal plant materials are classified by numbers that indicate their nominal aperture size expressed in  $\mu\text{m}$ . The sieves are made of wire of uniform circular cross-section, and have the following specifications:

Number of sieve ( $\mu\text{m}$ )	Nominal size of aperture (mm)	Nominal diameter of wire (mm)	Approximate screening area (%)
2000	2.00	0.90	48
710	0.710	0.450	37
500	0.500	0.315	38
355	0.355	0.224	38
250	0.250	0.160	37
212	0.212	0.140	36
180	0.180	0.125	35
150	0.150	0.100	36
125	0.125	0.090	34
90	0.090	0.063	35
75	0.075	0.050	36
45	0.045	0.032	34

The sieves recommended here have been selected from among those conforming to ISO standard 565, 1990.

### **3. General advice on sampling**

The reliability of any conclusions drawn from the analysis of a sample will depend upon how well the sample represents the whole batch. General recommendations for the sampling of pharmaceutical materials in connection with quality control are provided in the thirty-first report of the WHO Expert Committee on Specifications for Pharmaceutical Preparations (8).

Because of the specific characteristics of medicinal plant materials, in particular their lack of homogeneity, special handling procedures are required in relation to sampling. The following procedures should be observed when selecting and preparing an average sample from a batch of material.

#### **Recommended procedures**

##### **Sampling of material in bulk**

Inspect each container or packaging unit for conformity with pharmacopoeia mono-graphs or other requirements regarding packaging and labelling. Check the condition of the package and note any defects that may influence the quality or stability of the contents (physical damage, moisture, etc.). Sample damaged containers individually.

If initial inspection indicates that the batch is uniform, take samples as follows. When a batch consists of five containers or packaging units, take a sample from each one. From a batch of 6-50 units, take a sample from five. In the case of batches of over 50 units, sample 10%, rounding up the number of units to the nearest multiple of ten. For example, a batch of 51 units would be sampled as for 60, i.e. take samples from six packages.

After opening, inspect the contents of the units selected for sampling for:

- organoleptic characteristics (colour, texture and odour);
- presentation of the material (raw, cut, crushed, compressed);
- the presence of admixtures, foreign matter (sand, glass particles, dirt), mould, or signs of decay;
- the presence of insects;
- the presence of packaging material originating from poor or degraded containers.

From each container or package selected, take three original samples, taking care to avoid fragmentation. Samples should be taken from the top, middle and bottom of the container. In the case of sacks and packages, the three samples should be taken by hand, the first from a depth of not less than 10 cm from the top and the second and third from the middle and bottom after cutting into the side of the package. Samples of seeds should be withdrawn with a grain probe. Material in boxes should first be sampled from the upper layer; then approximately half of the contents should be removed and a second sample taken. Finally after further removal of material, another sample should be taken

from the bottom. Samples should be as uniform as possible in mass. The three original samples should then be combined into a **pooled sample** which should be mixed carefully.

The **average sample** is obtained by quartering. Form the pooled sample, adequately mixed, into an even and square-shaped heap, and divide it diagonally into four equal parts. Take two diagonally opposite parts and mix carefully. Repeat the process as necessary until the required quantity, to within  $\pm 10\%$ , is obtained (100-200g for flowers and up to 10kg for certain roots). Any remaining material should be returned to the batch.

Using the same quartering procedure, divide the average sample into four **final samples**, taking care that each portion is representative of the bulk material. The final samples are tested for the following characteristics:

- degree of fragmentation (sieve test);
- identity and level of impurities;
- moisture and ash content;
- level of active ingredients, where possible.

A portion of each final sample should be retained to serve as reference material, which may also be used for re-test purposes, if necessary.

#### **Sampling of material in retail packages**

From each wholesale container (boxes, cartons, etc.) selected for sampling, take at random two consumer packages. From small batches (1-5 boxes), take ten consumer packages. Prepare the **pooled sample** by mixing the contents of the selected consumer packages and proceed as described above to obtain **the final sample**.

## 4. Determination of foreign matter

Medicinal plant materials should be entirely free from visible signs of contamination by moulds or insects, and other animal contamination, including animal excreta. No abnormal odour, discoloration, slime or signs of deterioration should be detected. It is seldom possible to obtain marketed plant materials that are entirely free from some form of innocuous foreign matter. However, no poisonous, dangerous or otherwise harmful foreign matter or residue should be allowed.

During storage, products should be kept in a clean and hygienic place, so that no contamination occurs. Special care should be taken to avoid formation of moulds, since they may produce aflatoxins.

Macroscopic examination can conveniently be employed for determining the presence of foreign matter in whole or cut plant materials. However, microscopy is indispensable for powdered materials.

Any soil, stones, sand, dust and other foreign inorganic matter must be removed before medicinal plant materials are cut or ground for testing.

### Definition

Foreign matter is material consisting of any or all of the following:

- parts of the medicinal plant material or materials other than those named with the limits specified for the plant material concerned;
- any organism, part or product of an organism, other than that named in the specification and description of the plant material concerned;
- mineral admixtures not adhering to the medicinal plant materials, such as soil, stones, sand, and dust.

### Sample size

It is difficult to prepare a pooled sample of foreign matter since most of it adheres to the medicinal plant materials which are intrinsically non-uniform. Special procedures requiring considerable practice are therefore necessary. The problem is especially difficult when the samples of unbroken crude medicinal plant materials selected are small; they should be sufficiently large to be representative.

The following quantities constitute a sample, unless otherwise specified in the test procedure for the plant material concerned.

<i>Plant material</i>	<i>Sample size</i>
roots, rhizomes and bark	500 g
leaves, flowers, seeds and fruit	250 g
cut medicinal plant materials (average weight of each fragment less than 0.5 g)	50g

## **Recommended procedures**

### **Foreign matter in whole or cut medicinal plant materials**

Weigh a sample of plant material, taking the quantity indicated above unless other-wise specified in the test procedures for the plant material concerned. Spread it in a thin layer and sort the foreign matter into groups either by visual inspection, using a magnifying lens (6x or 10x), or with the help of a suitable sieve, according to the requirements for the specific plant material. Sift the remainder of the sample through a No. 250 sieve; dust is regarded as mineral admixture. Weigh the portions of this sorted foreign matter to within 0.05g. Calculate the content of each group in grams per 100g of air-dried sample.

For some medicinal plant materials where the foreign matter may closely resemble the material itself, it may be necessary to take a pooled sample of the plant material and apply a critical test, either chemical, physical or by microscopy. The proportion of foreign matter is calculated from the sum of the portions that fail to respond to the test.

## **5. Macroscopic and microscopic examination**

Medicinal plant materials are categorized according to sensory, macroscopic and microscopic characteristics. An examination to determine these characteristics is the first step towards establishing the identity and the degree of purity of such materials, and should be carried out before any further tests are undertaken. Wherever possible, authentic specimens of the material in question and samples of pharmacopoeial quality should be available to serve as a reference.

Visual inspection provides the simplest and quickest means by which to establish identity, purity and, possibly, quality. If a sample is found to be significantly different, in terms of colour, consistency, odour or taste, from the specifications, it is considered as not fulfilling the requirements. However, judgement must be exercised when considering odour and taste, owing to variability in assessment from person to person or by the same person at different times.

Macroscopic identity of medicinal plant materials is based on shape, size, colour, surface characteristics, texture, fracture characteristics and appearance of the cut surface. However, since these characteristics are judged subjectively and substitutes or adulterants may closely resemble the genuine material, it is often necessary to substantiate the findings by microscopy and/or physicochemical analysis.

Microscopic inspection of medicinal plant materials is indispensable for the identification of broken or powdered materials; the specimen may have to be treated with chemical reagents. An examination by microscopy alone cannot always provide complete identification, though when used in association with other analytical methods it can frequently supply invaluable supporting evidence.

Comparison with a reference material will often reveal characteristics not described in the requirements which might otherwise have been attributed to foreign matter, rather than normal constituents.

Any additional useful information for preparation or analysis should also be included in the test procedures for individual plant materials, for example, the determination of vein-islets and the palisade ratio.

### **Visual examination and odour**

Wrinkled and contracted leaves, herbs or flowers should be softened and stretched flat (see, p. 12 "Preliminary treatment"). Certain fruits and seeds may also require softening before dissection and observation of internal characteristics. No other preliminary treatment is required.



## Recommended procedures

### *Size*

A graduated ruler in millimetres is adequate for the measurement of the length, width and thickness of crude materials. Small seeds and fruits may be measured by aligning 10 of them on a sheet of calibrated paper, with 1 mm spacing between lines, and dividing the result by 10.

### *Colour*

Examine the untreated sample under diffuse daylight. If necessary, an artificial light source with wavelengths similar to those of daylight may be used. The colour of the sample should be compared with that of a reference sample.

### *Surface characteristics, texture and fracture characteristics*

Examine the untreated sample. If necessary, a magnifying lens (6x to 10x) may be used. Wetting with water or reagents, as required, may be necessary to observe the characteristics of a cut surface. Touch the material to determine if it is soft or hard; bend and rupture it to obtain information on brittleness and the appearance of the fracture plane - whether it is fibrous, smooth, rough, granular, etc.

### *Odour*

If the material is expected to be innocuous, place a small portion of the sample in the palm of the hand or a beaker of suitable size, and slowly and repeatedly inhale the air over the material. If no distinct odour is perceptible, crush the sample between the thumb and index finger or between the palms of the hands using gentle pressure. If the material is known to be dangerous, crush by mechanical means and then pour a small quantity of boiling water onto the crushed sample in a beaker. First, determine the strength of the odour (none, weak, distinct, strong) and then the odour sensation (aromatic, fruity, musty, mouldy, rancid, etc.). A direct comparison of the odour with a defined substance is advisable (e.g. peppermint should have an odour similar to menthol, cloves an odour similar to eugenol).

### *Taste*

**N.B. This test should be applied only if specifically required for a given plant material.**

## Inspection by microscopy

Once the material has been examined and classified according to external characteristics, inspection by microscopy can be carried out as the next step.

## Equipment

The following are required:

- a microscope equipped with lenses providing a wide range of magnification and a substage condenser, a graduated mechanical stage, objectives with a magnification of 4x, 10x, and 40x, and colour filters of ground glass, blue-green; high eyepoint eyepieces are preferred for wearers of spectacles;

- a lamp, either separate or incorporated into the microscope;
- a set of polarizing filters;
- a stage micrometer and an ocular micrometer to be inserted into a 6x eyepiece and placed on the diaphragm or, preferably, a micrometer eyepiece;
- a set of drawing attachments for the microscope;
- a microburner (Bunsen type);
- slides and cover-glasses of standard size;
- a set of botanical dissecting instruments.

## **Recommended procedures**

### **Preliminary treatment**

Select a representative sample of the material. Dried parts of a plant may require softening before preparation for microscopy, preferably by being placed in a moist atmosphere, or by soaking in water. For small quantities of material, place a wad of cotton-wool moistened with water into the bottom of a test-tube and cover with a piece of filter-paper. Place the material being examined on the paper, stopper the tube and allow to stand overnight or until the material is soft and suitable for cutting. Use a desiccator for larger quantities of material, placing water into the lower part instead of the drying agent.

Bark, wood and other dense and hard materials usually need to be soaked in water or equal parts of water, ethanol and glycerol for a few hours or overnight until they are soft enough to be cut. Boiling in water for a few minutes may sometimes be necessary.

Any water-soluble contents can be removed from the cells by soaking in water. Starch grains can be gelatinized by heating in water. In certain cases, material can be moistened with water for a few minutes to soften the surfaces and allow sections to be cut.

### **Preparation of specimens**

#### *Powdered materials*

Place 1 or 2 drops of water, glycerol/ethanol TS or chloral hydrate TS on a glass slide. Moisten the tip of a needle with water and dip into the powder. Transfer a small quantity of the material that adheres to the needle tip into the drop of fluid on the slide. Stir thoroughly, but carefully, and apply a cover-glass. Press lightly on the cover-glass with the handle of the needle, and remove excess fluid from the margin of the cover-glass with a strip of filter-paper. Other fluids may be used, if necessary, in the same manner.

If the specimen is to be freed from air bubbles, boil carefully over a small flame of a microburner until the air is completely removed. Care should be taken to replace the fluid that evaporates so that the space beneath the cover-glass is completely filled with fluid at the conclusion of the operation.

*Surface tissues of leaves and flowers*

To render pieces of thin leaves transparent, boil them directly on a slide. Cut a piece of leaf into two portions, turn one piece upper side down and add chloral hydrate TS. Boil the specimen carefully over a small flame of a microburner and, as soon as bubbles escape, remove the slide from the flame. When the bubbles have ceased to appear, boil again until the fragments are transparent.

For slightly thicker but still papery leaves, cut square pieces, about 6 mm from the edge of the leaf, if not otherwise specified. The pieces should be taken one-third to one-half of the way from the leaf-base and should include a midrib or large vein. In addition, cut 1 or 2 pieces from the edge including 1 or 2 indentations, where appropriate. For broken or cut leaves take suitable fragments as described above. Place the fragments in a test-tube containing chloral hydrate TS and boil for a few minutes until they become transparent. Transfer a fragment to a slide and cut it into two equal portions. Turn one piece upper side down and align the two pieces so that both upper and lower surfaces can be observed under the microscope. Add 1-2 drops of chloral hydrate TS and apply a cover-glass.

For thicker leaves, that do not become transparent enough when prepared by the method described above, clarify fragments by boiling with chloral hydrate TS in a test-tube. Transfer a fragment onto a slide, cut it into two equal portions and turn one portion upper side down. Scrape the surface of the two portions using a scalpel until only a single layer of epidermis remains. Wash the epidermis with drops of chloral hydrate TS or glycerol /ethanol TS to remove any residues. If possible, turn both parts of the epidermis upper side down, and add one of the above fluids.

For very thick or fleshy leaves, pull off the upper and lower parts of epidermis by winding the softened leaf around the index finger, pressing with the thumb and the middle finger against the index finger and carefully incising, catching the incised part with forceps, and bending the epidermis backwards carefully. Petals and sepals of flowers may be treated in a similar manner.

*Sections*

Select representative pieces of the material being examined and cut into suitable lengths, one end of which is softened and smoothed. Prepare cross or transverse sections by cutting with a razor blade or microtome at a right angle to the longitudinal axis of the material. Prepare longitudinal sections by cutting in parallel with the longitudinal axis, either in a radial direction (radial section) or in a tangential direction (tangential section).

Thick materials, such as wood, woody stems, rhizomes and roots can be cut by holding the softened material between the thumb and index finger, supported by the middle finger or by holding it in the central hole of a hand microtome. Thin materials such as leaves, petals and slender stems should be bound between two halves of a piece of elder-pith or other suitable support. If necessary, moisten the surface to be cut and the blade with ethanol (~375 g/l) TS. Cut the sections as thinly and evenly as possible. Transfer the sections with a

brush moistened with ethanol (~150g/l) TS to a dish containing ethanol (~150g/l) TS. Select satisfactory sections for the preparation of the slides. For certain materials a sliding microtome may be used.

Seeds and fruits that are very flat, or that are small and spherical, and cannot be held in the manner described above may be inserted into a notch cut into a small rubber stopper or embedded in hard paraffin (paraffin wax) as follows. Prepare a hard paraffin block, rectangular in shape, measuring about 7 x 7 x 15 mm, and melt a small hole in the centre of one end using a heated needle or thin glass rod. Press the material, which should be dry or softened by exposure to moisture, into this hole. Then prepare sections with a microtome.

For the examination of mucilage, aleurone grains or spherical aggregations of inulin, cut the material without using water.

### **Clarification of microscopic particles**

The presence of certain cell contents, such as starch grains, aleurone grains, plastids, fats and oils, may render sections non-translucent and obscure certain characteristics. Reagents that dissolve some of these contents can be used in order to make the remaining parts stand out clearly or produce a penetrating effect. This renders the section more transparent and reveals details of the structures.

If the refractive index of the clarifying agent is close to that of the cell structure, the material being tested becomes almost invisible; if it differs appreciably, the material becomes markedly evident.

The most frequently used clarifying agents are described below (for the methods of preparation, see section 22, "Reagents and solutions").

#### *Chloral hydrate TS*

On gentle heating chloral hydrate TS dissolves starch grains, aleurone grains, plastids, and volatile oils, and expands collapsed and delicate tissue without causing any undue swelling of cell walls or distortion of the tissues. It has a refractive index ( $n_D^{20}$ ) of 1.44 -1.48. It is the best reagent for rendering calcium oxalate clearly evident and is particularly useful for small crystals. However, when allowed to stand, it slowly dissolves calcium oxalate, owing to an increase in acidity.

#### *Lactochloral TS*

Lactochloral TS has a similar use to chloral hydrate TS, but is usually applied to sections that are difficult to clarify. It may be used cold. Before use, any air present in the specimen should be removed by placing in a desiccator and applying a vacuum.

### *Lactophenol TS*

Lactophenol TS may be used cold or with heating. It has a refractive index ( $n_D^{20}$ ) of 1.44 and is useful for the preparation of fungi, pollen grains, most non-oily powders, and parasites such as mites and nematode worms. Sizes of starch grains can be measured accurately, but the concentric rings are usually invisible when prepared in this reagent. Crystals of calcium oxalate are clearly visible in lactophenol and shine brightly when illuminated with polarized light. This reagent dissolves calcium carbonate deposits with a slow effervescence, owing to the presence of lactic acid.

### *Sodium hypochlorite TS*

Sodium hypochlorite TS is used for bleaching deeply coloured sections. Immerse the sections in the solution for a few minutes until sufficiently bleached, wash with water and prepare the mount with glycerol/ethanol TS. The bleached sections give a negative reaction to lignin.

### *Solvents for fats and oils*

Xylene R and light petroleum R can be used to remove fats and oils from oily powders or sections. When necessary, immerse the material in the solvent for a short time, decant the liquid and wash the material with fresh solvent.

## **Histochemical detection of cell walls and contents**

Reagents can be applied to a powdered sample or a section on a slide by the following methods:

- Add drops of the reagent to the sample and apply a cover-glass, then irrigate using a strip of filter-paper as described below.
- Place drops of the reagent on one edge of the cover-glass of a prepared specimen. Place a strip of filter-paper at the opposite edge of the cover-glass to remove the fluid under the cover-glass by suction, causing the reagent to flow over the specimen.

Using the second method, the progress of the reaction may be observed under a microscope. Care should be taken to avoid using reagents or vapours that could attack the lenses or stages of the microscope.

### *Cellulose cell walls*

Add 1-2 drops of iodinated zinc chloride TS and allow to stand for a few minutes; alternatively, add 1 drop of iodine (0.1 mol/l) VS, allow to stand for 1 minute, remove excess reagent with a strip of filter-paper and add 1 drop of sulfuric acid (~1160g/l) TS; cellulose cell walls are stained blue to blue-violet. On the addition of 1-2 drops of cuoxam TS, the cellulose cell walls will swell and gradually dissolve.

### *Lignified cell walls*

Moisten the powder or section on a slide with a small volume of phloroglucinol TS and allow to stand for about 2 minutes or until almost dry. Add 1 drop of hydrochloric acid (~420 g/l) TS and apply a cover-glass; lignified cell walls are stained pink to cherry red.

*Suberized or cuticular cell walls*

Add 1-2 drops of sudan red TS and allow to stand for a few minutes or warm gently; suberized or cuticular cell walls are stained orange-red or red.

*Aleurone grains*

Add a few drops of iodine/ethanol TS; the aleurone grains will turn yellowish brown to brown. Then add a few drops of ethanolic trinitrophenol TS; the grains will turn yellow. Add about 1 ml of mercuric nitrate TS and allow to dissolve; the colour of the solution turns brick red. If the specimen is oily, render it fat-free by immersing and washing it in an appropriate solvent before carrying out the test.

*Calcium carbonate*

Crystals or deposits of calcium carbonate dissolve slowly with effervescence when acetic acid (~60g/l) TS or hydrochloric acid (~70g/l) TS is added.

*Calcium oxalate*

Crystals of calcium oxalate are insoluble in acetic acid (~60g/l) TS but dissolve in hydrochloric acid (~70g/l) TS without effervescence (if applied by irrigation the acid should be more concentrated); they also dissolve in sulfuric acid (~350g/l) TS, but needle-shaped crystals of calcium sulfate separate on standing after about 10 minutes. In polarized light, calcium oxalate crystals are birefringent. Calcium oxalate is best viewed after the sample has been clarified, e.g. with chloral hydrate TS.

*Fats, fatty oils, volatile oils and resins*

Add 1-2 drops of sudan red TS and allow to stand for a few minutes or heat gently, if necessary. The fatty substances are stained orange-red to red. Irrigate the preparation with ethanol (~750 g/l) TS and heat gently; the volatile oils and resins dissolve in the solvent, while fats and fatty oils (except castor oil and croton oil) remain intact.

*Hydroxyanthraquinones*

Add 1 drop of potassium hydroxide (~55 g/l) TS; cells containing 1,8-dihydroxyanthraquinones are stained red.

*Inulin*

Add 1 drop each of 1-naphthol TS and sulfuric acid (~1760g/l) TS; spherical aggregations of crystals of inulin turn brownish red and dissolve.

*Mucilage*

Add 1 drop of Chinese ink TS to the dry sample; the mucilage shows up as transparent, spherically dilated fragments on a black background. Alternatively, add 1 drop of thionine TS to the dry sample, allow to stand for about 15 minutes, then wash with ethanol (~188g/l) TS; the mucilage turns violet-red (cellulose and lignified cell walls are stained blue and bluish violet respectively).

### *Starch*

Add a small volume of iodine (0.02 mol/l) VS; a blue or reddish blue colour is produced. Alternatively, add a small volume of glycerol/ethanol TS and examine under a microscope with polarized light; birefringence is observed giving a Maltese cross effect with the arms of the cross intersecting at the hilum.

### *Tannin*

Add 1 drop of ferric chloride (50g/l) TS; it turns bluish black or greenish black.

### **Disintegration of tissues**

Cut the material into small pieces, about 2 mm thick and 5 mm long or into slices, about 1 mm thick (tangential longitudinal sections are preferred for woods or xylem from stems).

Use one of the following methods depending on the nature of the cell walls. For tissues with lignified cell walls use either method 1 or 2. For tissues where lignified cells are few or occur in small groups, use method 3.

#### *Method 1. Nitric acid and potassium chlorate*

Place the material in a test-tube containing about 5 ml of nitric acid (~500g/l) TS and heat to boiling. Add a small quantity of powdered potassium chlorate R and allow to react, warming gently if necessary to maintain a slight effervescence; add fresh quantities of powdered potassium chlorate R as needed. When the tissue appears to be almost completely bleached and shows a tendency to disintegrate, apply pressure with a glass rod to the material. If the material breaks, interrupt the reaction by pouring the contents of the test-tube into water. Allow the material to settle, decant it and wash it with fresh water until the acidity is removed. Transfer the material onto a slide and tease it out with a needle. Add 1 drop of glycerol/ethanol TS and apply a cover-glass. The disintegrated material gives a negative reaction for lignin.

#### *Method 2. Nitric acid and chromic acid*

Place the material in a small dish and heat with nitro-chromic acid TS until the material breaks easily when pressure is applied with a glass rod. Wash the material repeatedly with water and transfer onto a slide. Tease out the material, add 1 drop of glycerol/ethanol TS and apply a cover-glass. The disintegrated material gives a negative reaction for lignin.

This treatment can also be carried out on a slide. Place a moderately thick section of the material on a slide, add the reagent and allow to stand for about 20 minutes. Separate the cells by applying gentle pressure, or with a sliding movement of the cover-glass. This process is especially useful when the disintegration of the tissues of a section under the microscope needs to be observed to ascertain where isolated cells come from.

#### *Method 3. Caustic alkali method*

Place the material in a test-tube containing about 5 ml of potassium hydroxide (~110g/l) TS or sodium hydroxide (~80 g/l) TS, and heat on a water-bath for 15-30 minutes until a portion breaks easily when pressure is applied with a glass

rod. Decant the liquid and wash the softened material several times with fresh quantities of water. This method is particularly useful for the disintegration of bark, seeds, leaves and flowers, facilitating the elimination of fibres, scleroids, lactiferous tissues and epidermis. The disintegrated material gives a negative reaction for lignin.

### **Measurement of specimens**

#### *Equipment*

Use a microscope with an ocular micrometer to measure the size of small objects. The scales should be calibrated using a stage micrometer, consisting of a glass slide of usual size, upon which a scale is engraved or photographed, usually 1 or 2 mm long, in 0.1 and 0.01 mm divisions. The ocular micrometer consists of a small disc of glass, across the diameter of which a 100-line scale is engraved or photographed. The disc is placed into the eyepiece.

#### *Calibration of the ocular micrometer*

Place the ocular micrometer scale in the eyepiece of the microscope. Put the stage micrometer on the microscope stage and focus on the scale divisions. Both scales should be sharply defined in the field of view. Turn the eyepiece to place the scales in a parallel position and, if necessary, move the stage micrometer until the starting lines of both scales coincide (Fig. 1). Now find another point, as far along the scale as possible, where two other division lines are exactly superimposed. Count the number of divisions on the ocular micrometer and the corresponding length on the stage micrometer scale, in order to determine the length that is equivalent to one division on the ocular micrometer scale; for example, if 100 divisions on the ocular micrometer scale are equal to 30 divisions on the stage micrometer scale, since the divisions on the stage micrometer scale are 0.01 mm apart, 100 ocular micrometer divisions are equivalent to 0.30 mm, therefore each division on the ocular micro-meter scale represents 3.0  $\mu\text{m}$ . Since the calibrations apply only for a particular lens combination, it is advisable to determine and record the ocular micrometer values for the most frequently used combinations.



**Fig. 1. Alignment of the stage micrometer and the ocular micrometer**

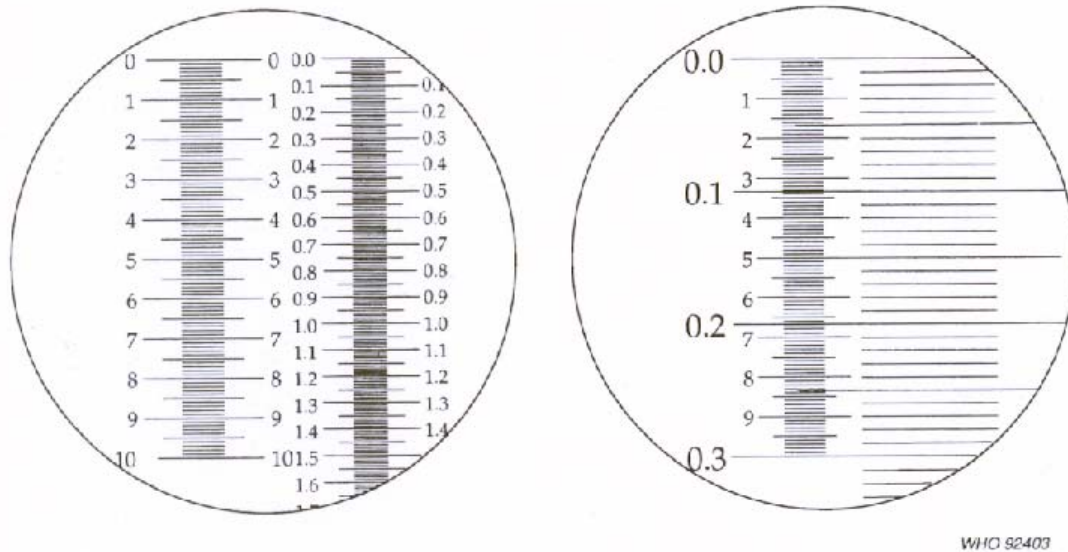

### *Method*

Place the specimen on the microscope stage and focus on the object to be measured. Superimpose the ocular micrometer scale and read off the dimensions of the object. Multiply the number of scale divisions by the micrometer value to give the actual dimension in micrometres. By this method, using a 40x objective and a 6x eyepiece, measurements are correct to the nearest 2  $\mu\text{m}$ , i.e. a dimension of 20  $\mu\text{m}$  is liable to an error of 2  $\mu\text{m}$ , or 10%, or  $\pm 5\%$ ; a dimension of 100  $\mu\text{m}$  is liable to an error of 2% or  $\pm 1\%$ .

For curved and elongated objects, the measurement of lengths may be made using a microscope equipped with a drawing apparatus or a camera lucida. The instrument should be set up so that the image of the object, the drawing paper and the pencil are in focus simultaneously. With the stage micrometer in place, trace the lines of the stage micrometer scale upon the paper fastened on a drawing board. Tilt the drawing board, if necessary, until the divisions drawn upon the paper are equally spaced. The magnification is determined by measuring the distance between selected lines on the drawing paper and dividing by the distance between the corresponding lines on the stage micrometer. Place the specimen on the microscope stage and trace the image of the object on the paper. Superimpose a coloured thread along the length of the object drawn on the paper and after straightening it, measure the length of the thread by means of a ruler graduated in millimetres; divide the measured length by the magnification to give the actual length of the object.

### **Leaf stomata**

#### *Types of stoma*

In the mature leaf, four significantly different types of stoma are distinguished by their form and the arrangement of the surrounding cells, especially the subsidiary cells (Fig. 2):

- The anomocytic or ranunculaceous (irregular-celled) type; the stoma is surrounded by a varying number of cells, generally not different from those of the epidermis.
- The anisocytic or cruciferous (unequal-celled) type; the stoma is usually surrounded by three or four subsidiary cells, one of which is markedly smaller than the others.
- The diacytic or caryophyllaceous (cross-celled) type; the stoma is accompanied by two subsidiary cells, the common wall of which is at right angles to the stoma.
- The paracytic or rubiaceous (parallel-celled) type; the stoma has two subsidiary cells, of which the long axes are parallel to the axis of the stoma.

In describing an epidermis where certain stomata differ from the predominant type, the term applying to the majority of stomata is used.

*Determination of the stomatal index*

Place fragments of leaves, about 5 x 5 mm in size, in a test-tube containing about 5 ml of chloral hydrate TS and heat on a water-bath for about 15 minutes or until

**Fig. 2. Types of leaf stoma**

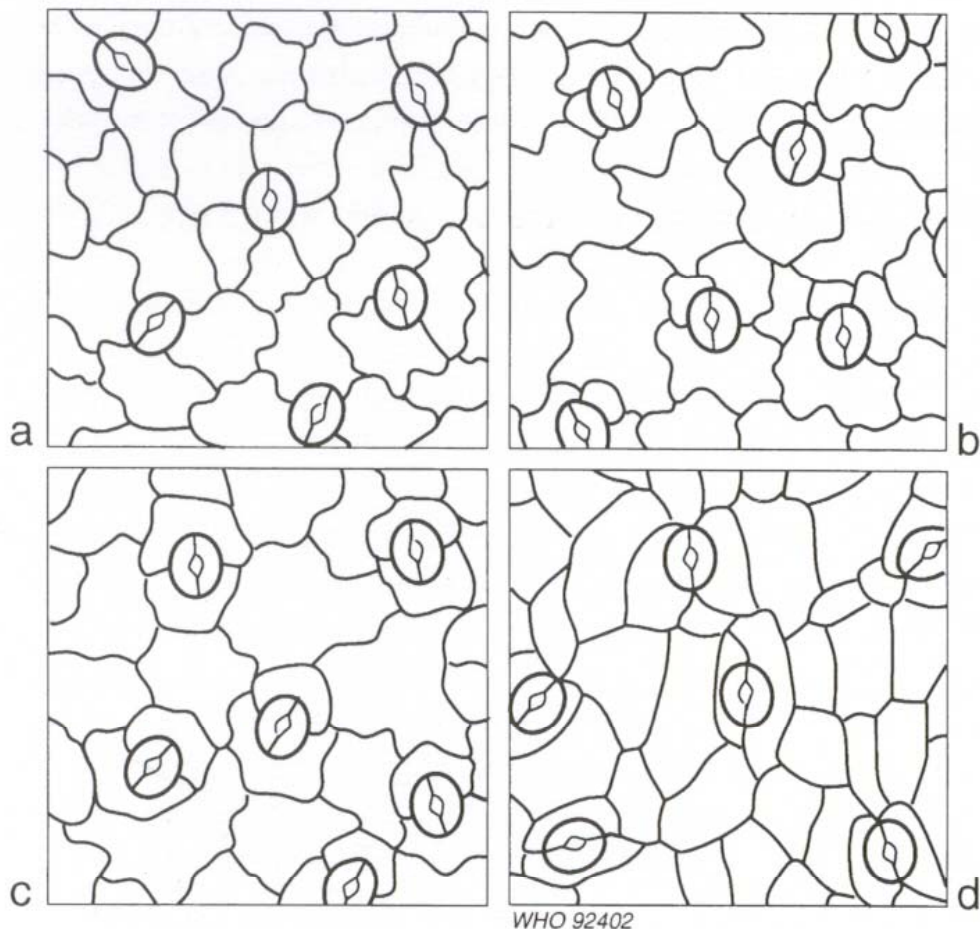

the fragments are transparent. Transfer a fragment to a slide and prepare it as described earlier, the lower epidermis uppermost, in chloral hydrate TS; place a small drop of glycerol/ethanol TS at one side of the cover-glass to prevent the material from drying. Examine under a microscope with a 40x objective and a 6x eyepiece, equipped with a drawing apparatus. Mark on the drawing paper a cross ( $\chi$ ) for each epidermal cell and a circle (o) for each stoma. Calculate the stomatal index as follows:

$$\text{stomatal index} = \frac{S \times 100}{E + S}$$

where S = the number of stomata in a given area of leaf

E = the number of epidermal cells (including trichomes) in the same area of leaf.

For each leaf sample, no fewer than ten determinations should be carried out and the average index calculated.

### **Microsublimation**

Mount a small, square metal plate, about 4 x 4 cm in size, on a square of a suitable board from which a central hole, about 1 cm in diameter, has been cut. Place a metal ring, about 1 cm in diameter and 8 mm in height, at the centre of the metal plate aligned with the hole of the asbestos board. Place about 0.1-0.2g of powdered material inside the ring to form an even layer, about 2 mm thick. Cover the ring with a clean slide. Heat gently and gradually over a small flame of a microburner. Change the slide if a large amount of moisture or sublimate is observed. Remove the slide from the ring, set it aside until the sublimate has dried and then examine under a microscope without adding any fluid and without a cover-glass. Prepare 4-5 slides in this manner.

A heating stage allows the temperature of sublimation to be recorded.

## 6. Thin-layer chromatography

Thin-layer chromatography is particularly valuable for the qualitative determination of small amounts of impurities. The principles of thin-layer chromatography and application of the technique in pharmaceutical analysis are described in volume 1 of *The international pharmacopoeia* (5). As it is effective and easy to perform, and the equipment required is inexpensive, the technique is frequently used for evaluating medicinal plant materials and their preparations.

The following parameters should be determined on the basis of published pharmacopoeial monographs or established experimentally for the analysis of each individual plant material:

- type of adsorbent and method of activation; if no information on the latter can be obtained, heat at 110°C for 30 minutes;
- method of preparation and concentration of the test and reference solutions;
- volume of the solutions to be applied on the plate;
- mobile phase and the distance of migration;
- drying conditions (including temperature) and method of detection;
- for the spots obtained:
  - number and approximate position, or the  $R_f$  values if necessary (see page 25), and
  - fluorescence and colour.

Two thin-layer chromatography methods are described below: the classical method and the micromethod, which uses different sizes of plates and hence different quantities of solvents.

### Classical method

#### Recommended procedures

The method outlined below assumes that chromatographic plates prepared in the laboratory are used but precoated plates, activated if necessary, may be used provided that they have proved suitable for the application concerned.

A powdered specimen of pharmacopoeial quality may be used as the reference material. If a test for the presence of a known active principle of a medicinal plant material is to be carried out, a chemical reference substance identical to that principle should be used. The test and reference solutions should be prepared simultaneously in exactly the same way. The reference solutions should be of known concentration. If the relative concentrations of the chemical substances in the reference solution are selected in accordance with the composition of a typical material, comparison of the spot size offers valuable additional information. The solvent system should be specified in the test procedure for the individual material being examined. A three-colour mixture (e.g. 0.01% solutions in toluene of indophenol blue, sudan red G and dimethyl yellow), run together, permits a rapid check on the prevailing chromatographic conditions.

If it is suspected that the materials being examined are unstable, the chamber in which chromatography takes place should be protected from light. In any case, the chromatographic chamber should always be kept out of direct sunlight. Otherwise, the rays of the sun may be refracted to different degrees owing to imperfections in the glass walls of the chamber, giving rise to areas of elevated temperature on the chromatographic plate and erratic flow of the mobile phase.

### **Preparation of samples**

Prior to testing, prepare an extract of the plant material to be examined, using a rapid extraction process, as follows. To 0.1-1.0g of the powdered plant material add 1-10 ml of solvent and extract either by stirring, shaking the mixture for 3-30 minutes, or heating to boiling and allowing to cool. Remove the insoluble matter by centrifugation, or filter through a small funnel with filter-paper or a cotton plug. If necessary, evaporate the filtrate on a water-bath for just as long as is required to remove the solvent, then re-dissolve the residue in a small volume of solvent (e.g. 0.1-0.2 ml). If necessary, purify the test solution by repeating the extraction with solvent at a different pH, or by sublimation, distillation, or other appropriate method.

### **Apparatus**

The equipment consists of:

- glass plates of uniform thickness throughout their entire area, 15-20 cm long, and wide enough to accommodate the required number of test and reference solutions;
- a device for spreading a uniform layer of coating material of desired thickness onto the glass plates;
- a rack to hold the prepared plates (normally 10 plates with set spacings) during the drying period or for transportation and storage; the rack should be small enough to fit in a drying oven and desiccator;
- a chromatographic chamber of transparent material, usually glass, with a tightly fitting lid, of suitable size to accommodate the test plates;
- a suitable spraying implement with a fine spray nozzle, made of a material resistant to the reagents to be used;
- an ultraviolet light source emitting short (254 nm) and long (365 nm) wavelengths.

Before use, clean the plates scrupulously by immersing in a suitable cleaning liquid and rinsing thoroughly until the water runs off the plates without leaving any visible water marks or oily spots, and then dry. The plates must be completely free of lint or dust when the coating material is applied.

### **Method**

#### *Preparation of the adsorbent*

Unless otherwise specified in the test procedure for the plant material concerned, prepare a slurry of the coating material and water or an aqueous solution (see section 21, "Specifications for adsorbents") and, using the spreading device, coat the cleaned plates with a layer about 0.25 mm thick. Dry the coated

plates in air, heat to activate at 110°C for 30 minutes, and then allow to cool. Inspect the uniformity of the coating in transmitted light and the texture in reflected light. If the plates are not to be used immediately, store them in a desiccator containing silica gel, desiccant, R. To form an edge remove a narrow strip (2-5 mm wide) of the coating material from the sides of the plate.

If acid, alkaline or buffered layers are required, use diluted acid, base or salt mixtures instead of water for the preparation of the slurry, as specified in the test procedure. An aqueous solution of 5-7 g of sodium carboxymethylcellulose R could replace the water, if the adsorbent does not already contain a binder.

#### *Saturation of the chromatographic chamber*

Unless otherwise specified in the test procedure, the chromatography is carried out in a saturated chamber. To achieve saturation, line at least half of the total area of the inside walls of the chamber with filter-paper, pour into the chamber a sufficient quantity of the mobile phase to saturate the filter-paper and form a layer about 5 mm deep. Close the chamber and allow to stand for at least 1 hour at room temperature.

All operations during which the plate is exposed to the air should preferably be carried out at a relative humidity of 50-60%, and the plates should be handled with care.

#### *Application of the test and reference solutions*

Using a micropipette or a syringe graduated in  $\mu\text{l}$ , place spots of the test and reference solutions onto the starting line, which should be parallel to and about 15 mm above the lower edge. The spots should be at least 15 mm from the sides of the plate, and at least 15 mm apart. They should be as small as possible, preferably not more than 4 mm in diameter; if necessary, apply the solution in portions, drying between applications. Mark the distance the mobile phase is intended to ascend as specified in the test procedure, usually 10-15 cm from the starting line.

The results of separation can often be improved by applying the solutions to form a horizontal band 10-15 mm long and not more than 5 mm wide.

#### *Development of chromatograms*

Allow the spots to dry, place the plate - as nearly vertical as possible - into the chamber, ensuring that the points of application are above the surface of the mobile phase. Close the chamber. Develop the chromatogram at room temperature, unless otherwise specified in the test procedure, allowing the solvent to ascend the specified distance. Remove the plate, mark the position of the solvent front and allow the solvent to evaporate at room temperature or as specified.

#### *Observation and interpretation of the chromatograms*

Observe the spots produced in daylight, then under short-wave and long-wave ultraviolet light. Mark the centre of each spot with a needle. Measure and record the distance from the centre of each spot to the point of application, and indicate

for each spot the wavelength under which it was observed. If indicated in the test procedure, spray the spots with the specified reagent, and observe and compare the spots with those of a reference material.

If required calculate the ratio of the distance travelled on the adsorbent by a given compound to that travelled by the leading edge of the solvent (the  $R_f$  value) or the ratio of the distances moved by a compound and a stated reference substance (the  $R_r$  value) as follows:

$$R_f = \frac{a}{b} \quad R_r = \frac{a}{c}$$

where  $a$  = the distance between the point of application and the centre of the spot of the material being examined;

$b$  = the distance between the point of application and the solvent front;

$c$  = the distance between the point of application and the centre of the spot of reference material.

$R_f$  values may vary with each experiment depending on the saturation conditions in the chromatographic chamber, the activity of the adsorbent layer, and the composition of the mobile phase.

## Micromethod

### Recommended procedures

The chromatograms can be developed either vertically or horizontally. Unless otherwise specified in the test procedure for the plant material concerned, thin-layer chromatography is performed on small plates using the ascending technique.

### *Ascending technique*

### Apparatus

The equipment consists of:

- precoated or specially prepared plates, not more than 100 mm long, and 100 mm wide, that permit development over at least 60 mm;
- 1- $\mu$ l or 2- $\mu$ l micropipettes accurate to  $\pm 10\%$  of the stated volume;
- a chromatographic chamber with a tightly fitting lid and a flat base; the chamber must be of such a size to accommodate the plates and the appropriate volume of the mobile phase.

### Method

Place a sufficient quantity of a previously mixed and homogeneous mobile phase into the chromatographic chamber to form a layer 5 mm deep. (Mobile phase mixtures should be discarded after the development of a plate.) Close the chamber and allow to stand at constant room temperature, protected from draughts and direct sunlight, for 15 minutes.

Using a micropipette, apply spots of the solutions being examined onto the starting line, which should be parallel to and about 10 mm above the lower edge of the plate. The spots should be at least 10 mm from the sides of the plate, and 5-10 mm apart. They should be as small as possible, preferably no more than 2 mm in diameter. Mark the distance the mobile phase is intended to ascend as specified in the test procedure for the plant material concerned, usually 60 mm from the starting line.

Allow the spots to dry, then place the plate - as nearly vertical as possible - into the chamber, ensuring that the points of application are above the surface of the mobile phase. The sides of the plate must not come into contact with the wall of the chamber. Close the chamber. Develop the chromatogram at room temperature, unless otherwise specified in the test procedure, allowing the solvent to ascend the specified distance. Remove the plate, mark the position of the solvent front and allow the solvent to evaporate at room temperature or as specified.

### *Horizontal technique*

#### **Apparatus**

The equipment consists of:

- specially made plates 50 mm long, 50 mm wide;
- 0.5- $\mu$ l or 1- $\mu$ l micropipettes, accurate to  $\pm 10\%$  of the stated volume;
- a chromatographic chamber for horizontal development (Fig. 3); commercially available chambers consist of a solvent-proof body with a trough for the mobile phase and a tightly fitting glass lid; the mobile phase is transferred from the trough to the adsorbent layer via an exchangeable sintered-glass plate.

**Fig. 3. Chromatographic chamber for horizontal development (horizontal cross-section)**

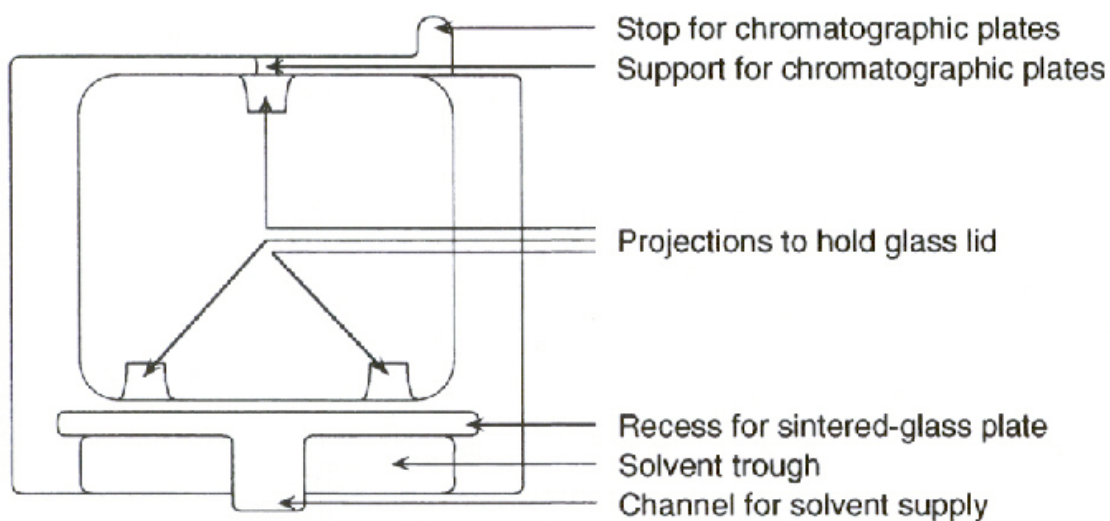



## **Method**

Protect the chromatographic chamber from draughts and direct sunlight, and keep it at constant room temperature. Place a clean, dry sintered-glass plate into the chamber. (After each use, the sintered-glass plate should be cleaned with acetone R and dried.)

If saturation is required, line the floor of the chamber with filter paper and pour the required quantity of saturation liquid onto it. Should more intensive saturation of the chamber be required, use, in addition, a ready-made silica gel plate, cut to size, and saturated with the liquid. As an alternative a sandwich-type plate can be used with a dry silica gel plate.

Using a micropipette, apply the volumes of the solutions to be examined onto the starting line of the chromatographic plate, which should be parallel to the lower edge of the plate. The spots produced should be at least 7 mm from the sides of the plate and not less than 5 mm apart. The spots should be as small as possible, preferably no more than 1 mm in diameter. Mark the distance the mobile phase is intended to travel as specified in the test procedure, for the plant material concerned, usually 40 mm from the starting line.

Allow the spots to dry, place the plate into the chamber with the coating downwards so as to be in contact with the sintered-glass plate across the whole width. The points of application should be about 3 mm from the edge of the sintered-glass plate. Close the chamber with the lid, leaving the trough for the mobile phase open. Using a pipette place the required volume of previously mixed homogeneous mobile phase, usually 1-2 ml, into the trough and immediately close the chamber. Develop the chromatogram at room temperature, unless otherwise indicated in the test procedure, allowing the solvent to travel the specified distance. Remove the plate, mark the position of the solvent front and allow the solvent to evaporate at room temperature or as specified.

## 7. Determination of ash

The ash remaining following ignition of medicinal plant materials is determined by three different methods which measure total ash, acid-insoluble ash and water-soluble ash.

The *total ash* method is designed to measure the total amount of material remaining after ignition. This includes both "physiological ash", which is derived from the plant tissue itself, and "non-physiological" ash, which is the residue of the extraneous matter (e.g. sand and soil) adhering to the plant surface.

*Acid-insoluble ash* is the residue obtained after boiling the total ash with dilute hydrochloric acid, and igniting the remaining insoluble matter. This measures the amount of silica present, especially as sand and siliceous earth.

*Water-soluble ash* is the difference in weight between the total ash and the residue after treatment of the total ash with water.

### Recommended procedures

#### Total ash

Place about 2-4g of the ground air-dried material, accurately weighed, in a previously ignited and tared crucible (usually of platinum or silica). Spread the material in an even layer and ignite it by gradually increasing the heat to 500-600°C until it is white, indicating the absence of carbon. Cool in a desiccator and weigh. If carbon-free ash cannot be obtained in this manner, cool the crucible and moisten the residue with about 2 ml of water or a saturated solution of ammonium nitrate R. Dry on a water-bath, then on a hot-plate and ignite to constant weight. Allow the residue to cool in a suitable desiccator for 30 minutes, then weigh without delay. Calculate the content of total ash in mg per g of air-dried material.

#### Acid-insoluble ash

To the crucible containing the total ash, add 25 ml of hydrochloric acid (~70g/l) TS, cover with a watch-glass and boil gently for 5 minutes. Rinse the watch-glass with 5 ml of hot water and add this liquid to the crucible. Collect the insoluble matter on an ashless filter-paper and wash with hot water until the filtrate is neutral. Transfer the filter-paper containing the insoluble matter to the original crucible, dry on a hot-plate and ignite to constant weight. Allow the residue to cool in a suitable desiccator for 30 minutes, then weigh without delay. Calculate the content of acid-insoluble ash in mg per g of air-dried material.

#### Water-soluble ash

To the crucible containing the total ash, add 25 ml of water and boil for 5 minutes. Collect the insoluble matter in a sintered-glass crucible or on an ashless filter-paper. Wash with hot water and ignite in a crucible for 15 minutes at a temperature not exceeding 450°C. Subtract the weight of this residue in mg from the weight of total ash. Calculate the content of water-soluble ash in mg per g of air-dried material.

## **8. Determination of extractable matter**

This method determines the amount of active constituents extracted with solvents from a given amount of medicinal plant material. It is employed for materials for which as yet no suitable chemical or biological assay exists.

### **Recommended procedures**

#### **Method 1. Hot extraction**

Place about 4.0g of coarsely powdered air-dried material, accurately weighed, in a glass-stoppered conical flask. Add 100ml of water and weigh to obtain the total weight including the flask. Shake well and allow to stand for 1 hour. Attach a reflux condenser to the flask and boil gently for 1 hour; cool and weigh. Readjust to the original total weight with the solvent specified in the test procedure for the plant material concerned. Shake well and filter rapidly through a dry filter. Transfer 25 ml of the filtrate to a tared flat-bottomed dish and evaporate to dryness on a water-bath. Dry at 105°C for 6 hours, cool in a desiccator for 30 minutes, then weigh without delay. Calculate the content of extractable matter in mg per g of air-dried material.

#### **Method 2. Cold maceration**

Place about 4.0g of coarsely powdered air-dried material, accurately weighed, in a glass-stoppered conical flask. Macerate with 100ml of the solvent specified for the plant material concerned for 6 hours, shaking frequently, then allow to stand for 18 hours. Filter rapidly taking care not to lose any solvent, transfer 25 ml of the filtrate to a tared flat-bottomed dish and evaporate to dryness on a water-bath. Dry at 105°C for 6 hours, cool in a desiccator for 30 minutes and weigh without delay. Calculate the content of extractable matter in mg per g of air-dried material.

For ethanol-soluble extractable matter, use the concentration of solvent specified in the test procedure for the plant material concerned; for water-soluble extractable matter, use water as the solvent. Use other solvents as specified in the test procedure.

## 9. Determination of water and volatile matter

An excess of water in medicinal plant materials will encourage microbial growth, the presence of fungi or insects, and deterioration following hydrolysis. Limits for water content should therefore be set for every given plant material. This is especially important for materials that absorb moisture easily or deteriorate quickly in the presence of water.

The *azeotropic* method gives a direct measurement of the water present in the material being examined. When the sample is distilled together with an immiscible solvent, such as toluene R or xylene R, the water present in the sample is absorbed by the solvent. The water and the solvent are distilled together and separated in the receiving tube on cooling. If the solvent is anhydrous, water may remain absorbed in it leading to false results. It is therefore advisable to saturate the solvent with water before use.

The test for *loss on drying* determines both water and volatile matter. Drying can be carried out either by heating to 100-105 °C or in a desiccator over phosphorus pentoxide R under atmospheric or reduced pressure at room temperature for a specified period of time. The desiccation method is especially useful for materials that melt to a sticky mass at elevated temperatures.

### Recommended procedures

#### Preparation of material

Prepare a suitable quantity of the sample by cutting, granulating or shredding the unground or unpowdered material, so that the thickness of the parts does not exceed 3 mm. Seeds or fruits smaller than 3 mm should be cracked. Avoid the use of high-speed mills in preparing the sample, and take care that no appreciable amount of moisture is lost during preparation. It is important that the portion is large enough to be a representative sample.

#### Azeotropic method (toluene distillation)

The apparatus (Fig. 4) consists of a glass flask (A) connected by a tube (D) to a cylindrical tube (B) fitted with a graduated receiving tube (E) and a reflux condenser (C). The receiving tube (E) is graduated in 0.1-ml divisions so that the error of readings does not exceed 0.05 ml. The preferred source of heat is an electric heater with a rheostat control, or an oil-bath. The upper portion of the flask and the connecting tube may be insulated.

Thoroughly clean the receiving tube and the condenser of the apparatus, rinse with water and dry. Introduce 200 ml of toluene R and about 2 ml of water into a dry flask. Heat the flask to distil the liquid over a period of 2 hours, allow to cool for about 30 minutes and read off the volume of water to an accuracy of 0.05 ml (first distillation).

Weigh accurately a quantity of the material expected to give about 2-3 ml of water and transfer to the flask. (For weighing material with a paste-like character, use a boat of metal foil.) Add a few pieces of porous porcelain and

heat the flask gently for 15 minutes. When boiling begins, distil at a rate of 2 drops per second until most of the water has distilled over, then increase the rate of distillation to about 4 drops per second. As soon as the water has been completely distilled, rinse the inside of the condenser tube with toluene R. Continue the distillation for 5 more minutes, remove the heat, allow the receiving tube to cool to room temperature and dislodge any droplets of water adhering to the walls of the receiving tube by tapping the tube. Allow the water and toluene layers to separate and read off the volume of water (second distillation). Calculate the content of water as a percentage using the formula:

Fig. 4. Apparatus used to determine water content by the azeotropic method (dimensions in mm)

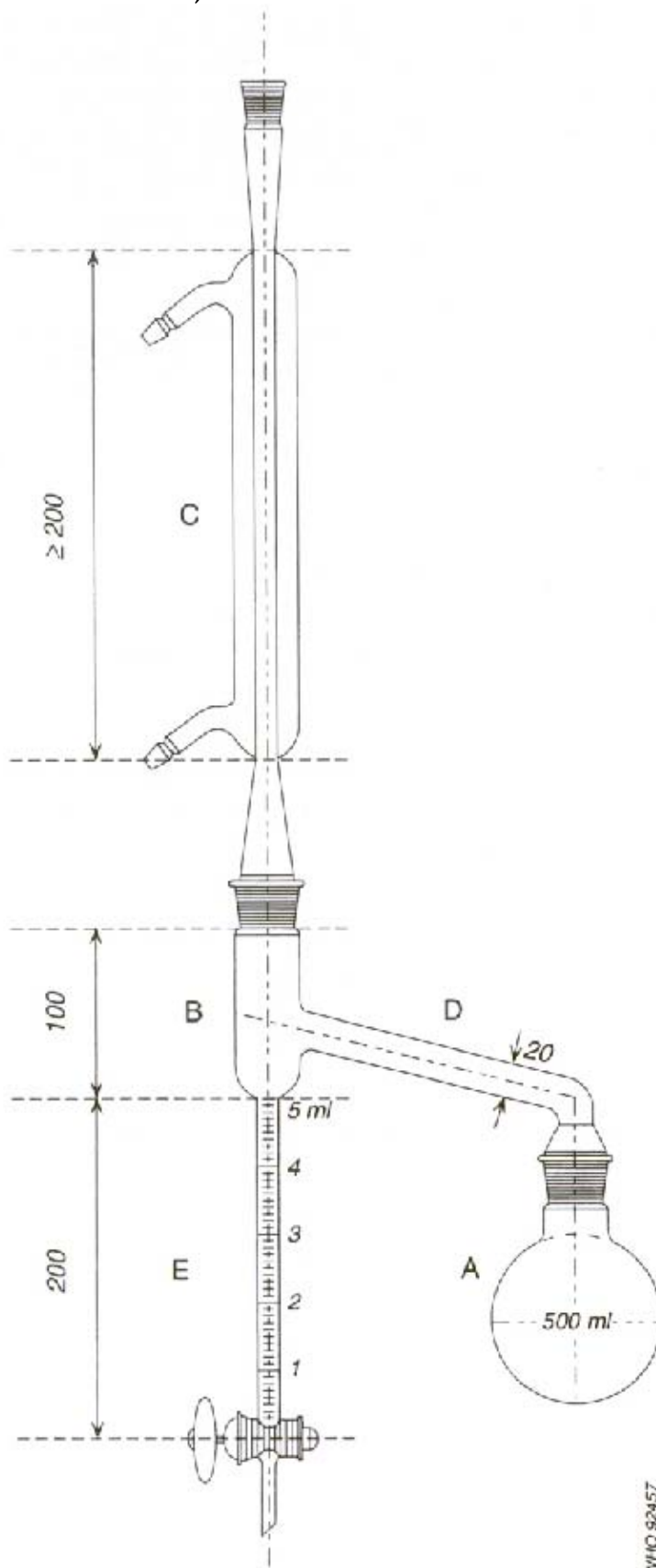

$$\frac{100(n_1 - n)}{w}$$

where  $w$  = the weight in g of the material being examined

$n$  = the number of ml of water obtained in the first distillation

$n_1$  = the total number of ml of water obtained in both distillations

**Loss on drying (gravimetric determination)**

Place about 2-5g of the prepared air-dried material, or the quantity specified in the test procedure for the plant material concerned, accurately weighed, in a previously dried and tared flat weighing bottle. Dry the sample by one of the following techniques:

- in an oven at 100-105°C;
- in a desiccator over phosphorus pentoxide R under atmospheric pressure or reduced pressure and at room temperature.

Dry until two consecutive weighings do not differ by more than 5mg, unless otherwise specified in the test procedure. Calculate the loss of weight in mg per g of air-dried material.

## **10. Determination of volatile oils**

Volatile oils are characterized by their odour, oil-like appearance and ability to volatilize at room temperature. Chemically, they are usually composed of mixtures of, for example, monoterpenes, sesquiterpenes and their oxygenated derivatives. Aromatic compounds predominate in certain volatile oils.

Because they are considered to be the "essence" of the plant material, and are often biologically active, they are also known as "essential oils". The term "volatile oil" is preferred because it is more specific and describes the physical properties.

In order to determine the volume of oil, the plant material is distilled with water and the distillate is collected in a graduated tube. The aqueous portion separates automatically and is returned to the distillation flask. If the volatile oils possess a mass density higher than or near to that of water, or are difficult to separate from the aqueous phase owing to the formation of emulsions, a solvent with a low mass density and a suitable boiling-point may be added to the measuring tube. The dissolved volatile oils will then float on top of the aqueous phase.

### **Recommended procedure**

Carry out the determination by steam distillation. Collect the distillate in a graduated tube, using xylene R or the solvent specified for the plant material concerned, and allow the aqueous phase to recirculate into the distillation flask. For all determinations read the rate of distillation from the marks engraved on the apparatus.

### **Apparatus**

A suitable apparatus is made from resistant glass with a low expansion coefficient, and has the following parts:

- a round-bottomed, short-necked flask, capacity 500 or 1000 ml, the internal diameter of the ground-glass neck being 29 mm at the widest end;
- the following sections fused into one piece (Fig. 5):
  - a vertical tube (AC), 210-260 mm long, with an external diameter of 13-15 mm;
  - a bent tube (CDE), CD and DE each being 145-155 mm long, and having an external diameter of 10 mm;
  - a bulb-condenser (FG), 145-155 mm long;
  - a tube (GH) 30-40 mm long, with a side-arm tube (HK), at an angle of 30-40°;
  - a vented ground-glass stopper (K') and a tube (K) with an internal diameter of 10 mm, the wide end being of ground glass;
  - a pear-shaped bulb (J) with a volume of 3 ml;
  - a tube with a volume of 1 ml (JL), graduated over 100-110 mm in divisions of 0.01 ml;



Fig. 5. Apparatus used to determine volatile oils (dimensions in mm)<sup>1</sup>

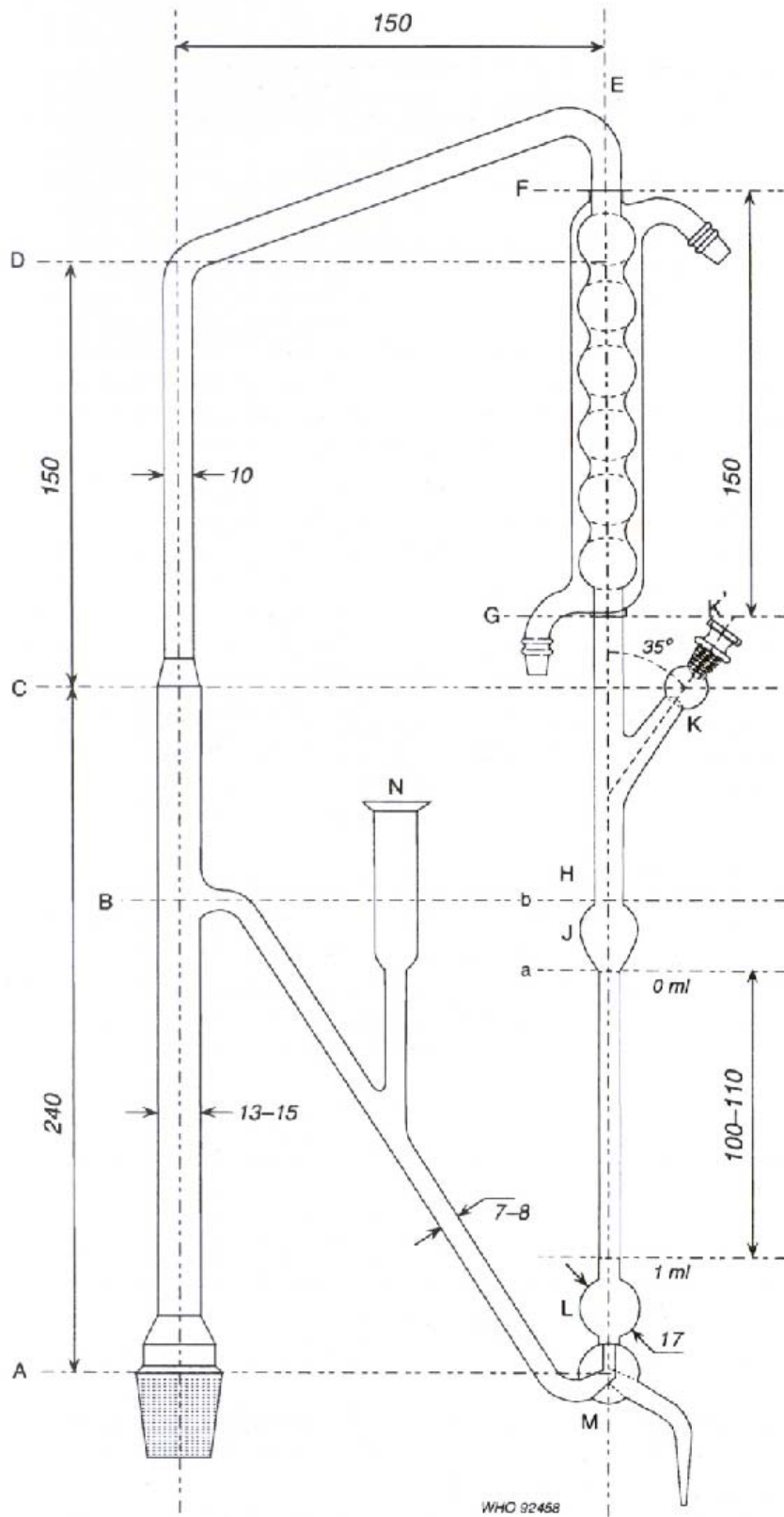

<sup>1</sup> For reasons of clarity, the 0.01-ml graduations are not shown on the tube JL.

- a bulb-like swelling (L), with a volume of about 2 ml;
- a three-way tap (M);
- a connecting tube (BM), with an external diameter of 7-8 mm, which is fitted in the middle with a security tube (N); the junction (B) should be 20-25 mm higher than the uppermost graduation;
- a burner allowing fine control and fitted with a flue, or an electric heating device;
- a vertical support with a horizontal ring covered with insulating material.

Before use, clean the apparatus thoroughly by successive washings, for example with acetone R or a suitable detergent, then rinse with water, drain and assemble in a suitable place.

### **Preparation of the sample**

The preparation of the sample depends on the texture of the material and the location of the volatile oils. Hard and compact plant material (e.g. bark, roots or rhizomes), or material containing volatile oils in the cells or small cavities of the tissue, should be coarsely powdered; thick leaves should be finely cut or lightly bruised; materials such as citrus peel are preferably crushed under water, as the volatile oils in large schizolysigenous cavities are easily lost during the process of comminution. Material consisting of thin floral parts or thin laminae or containing volatile oils in the epidermal glands should be distilled whole.

### **Method**

Place the volume of distillation liquid specified in the test procedure for the plant material concerned in the flask, add a few pieces of porous porcelain and join the condenser to the apparatus. Introduce water by tube N until it reaches level B. Remove stopper (K') and introduce the appropriate volume of xylene R or the solvent specified for the given plant material, using a graduated pipette and placing its tip at the bottom of tube K. Replace stopper, heat the liquid in the flask until it begins to boil and adjust the distillation rate to 2-3 ml per minute, unless otherwise specified in the test procedure.

To determine the distillation rate, lower the level of water while distilling by means of the three-way tap until the meniscus is at the level of the lower mark (see Fig. 6). Close the tap and simultaneously start a stop-watch. As soon as the level in the bulb reaches the upper mark, stop the watch and note the time taken. Open the tap and continue the distillation. Stop the heating after 30 minutes, turn off the heater, wait at least 10 minutes and then record the volume of solvent (xylene) collected in the graduated tube.

Introduce the specified quantity of the plant material being examined into the flask and continue the distillation as described above for the time and at the rate

**Fig. 6. Determination of distillation rate**

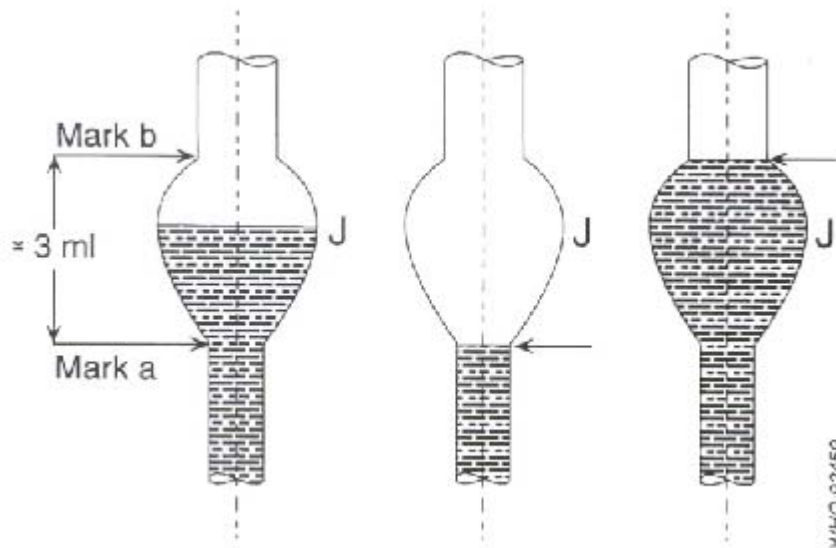

given in the test procedure. After a further 10 minutes record the volume of oil collected in the graduated tube and subtract the volume of solvent (xylene) previously noted. The difference represents the volume of volatile oils in the sample of plant material taken. Calculate the oil content in ml per 100g of plant material.

## **11. Determination of bitterness value**

Medicinal plant materials that have a strong bitter taste ("bitters") are employed therapeutically, mostly as appetizing agents. Their bitterness stimulates secretions in the gastrointestinal tract, especially of gastric juice.

Bitter substances can be determined chemically. However, since they are mostly composed of two or more constituents with various degrees of bitterness, it is first necessary to measure total bitterness by taste.

The bitter properties of plant material are determined by comparing the threshold bitter concentration of an extract of the materials with that of a dilute solution of quinine hydrochloride R. The bitterness value is expressed in units equivalent to the bitterness of a solution containing 1g of quinine hydrochloride R in 2000 ml.

Safe drinking-water should be used as a vehicle for the extraction of plant materials and for the mouth-wash after each tasting. Taste buds dull quickly if distilled water is used. The hardness of water rarely has any significant influence on bitterness.

Sensitivity to bitterness varies from person to person, and even for the same person it may be different at different times (because of fatigue, smoking, or after eating strongly flavoured food). Therefore, the same person should taste both the material to be tested and the quinine hydrochloride solution within a short space of time. The bitter sensation is not felt by the whole surface of the tongue, but is limited to the middle section of the upper surface of the tongue. A certain amount of training is required to perform this test. A person who does not appreciate a bitter sensation when tasting a solution of 0.058 mg of quinine hydrochloride R in 10 ml of water is not suitable to undertake this determination.

The preparation of the stock solution of each individual plant material ( $S_T$ ) should be specified in the test procedure. In each test series, unless otherwise indicated, the determination should start with the lowest concentration in order to retain sufficient sensitivity of the taste buds.

### **Recommended procedure**

**Caution: This test should not be carried out until the identity of the plant material has been confirmed.**

### **Preparation of solutions**

#### *Stock and diluted quinine hydrochloride solutions*

Dissolve 0.100g of quinine hydrochloride R in sufficient safe drinking-water to produce 100 ml. Further dilute 5 ml of this solution to 500 ml with safe drinking-

Table 1  
**Determination of bitterness value: serial dilution for the initial test**

Tube no.									
	1	2	3	4	5	6	7	8	9
$S_q$ (ml)	4.2	4.4	4.6	4.8	5.0	5.2	5.4	5.6	5.8
Safe drinking-water (ml)	5.8	5.6	5.4	5.2	5.0	4.8	4.6	4.4	4.2
Quinine hydrochloride in 10 ml of solution (= c) (mg)	0.042	0.044	0.046	0.048	0.050	0.052	0.054	0.056	0.058

$S_q$ , stock solution of quinine hydrochloride.

Table 2  
**Determination of bitterness value: serial dilution for the second test**

Tube no.										
	1	2	3	4	5	6	7	8	9	10
$S_T$ (ml)	1.00	2.00	3.00	4.00	5.00	6.00	7.00	8.00	9.00	10.0
Safe drinking-water (ml)	9.00	8.00	7.00	6.00	5.00	4.00	3.00	2.00	1.00	-

$S_T$ , stock solution of the plant material being examined.

water. This stock solution of quinine hydrochloride ( $S_q$ ) contains 0.01 mg/ml. Use nine test-tubes for the serial dilution for the initial test as indicated in Table 1.

*Stock and diluted solutions of the plant material*

Prepare the solution as specified in the test procedure for the given plant material ( $S_T$ ). Use 10 test-tubes for the serial dilution for the test as indicated in Table 2.

**Method**

After rinsing the mouth with safe drinking-water, taste 10ml of the most dilute solution swirling it in the mouth mainly near the base of the tongue for 30 seconds. If the bitter sensation is no longer felt in the mouth after 30 seconds,

spit out the solution and wait for 1 minute to ascertain whether this is due to delayed sensitivity. Then rinse with safe drinking-water. The next highest concentration should not be tasted until at least 10 minutes have passed. The threshold bitter concentration is the lowest concentration at which a material continues to provoke a bitter sensation after 30 seconds. After the first series of tests, rinse the mouth thoroughly with safe drinking-water until no bitter sensation remains. Wait for at least 10 minutes before carrying out the second test.

In order to save time in the second test, it is advisable to ascertain first whether the solution in tube no. 5 (containing 5 ml of  $S_T$  in 10 ml) gives a bitter sensation. If so, find the threshold bitter concentration of the material by tasting the dilutions in tubes 1-4. If the solution in tube no. 5 does not give a bitter sensation, find the threshold bitter concentration by tasting the dilutions in tubes 6-10.

All solutions and the safe drinking-water for mouthwashing should be at 20-25 °C.

Calculate the bitterness value in units per g using the following formula:  
 $2000 \times c$

$$\frac{2000 \times c}{a \times b}$$

where  $a$  = the concentration of the stock solution ( $S_T$ ) (mg/ml),  
 $b$  = the volume of  $S_T$  (in ml) in the tube with the threshold bitter concentration,  
 $c$  = the quantity of quinine hydrochloride R (in mg) in the tube with the threshold bitter concentration.

## **12. Determination of haemolytic activity**

Many medicinal plant materials, especially those derived from the families Caryophyllaceae, Araliaceae, Sapindaceae, Primulaceae, and Dioscoreaceae contain saponins. The most characteristic property of saponins is their ability to cause haemolysis: when added to a suspension of blood, saponins produce changes in erythrocyte membranes, causing haemoglobin to diffuse into the surrounding medium.

The haemolytic activity of plant materials, or a preparation containing saponins, is determined by comparison with that of a reference material, saponin R, which has a haemolytic activity of 1000 units per g. A suspension of erythrocytes is mixed with equal volumes of a serial dilution of the plant material extract. The lowest concentration to effect complete haemolysis is determined after allowing the mixtures to stand for a given period of time. A similar test is carried out simultaneously with saponin R.

Procedures proposed for the determination of the haemolytic activity of saponaceous medicinal plant material are all based on the same principle although the details may vary, e.g. the source of erythrocytes, methods for the preparation of the erythrocyte suspension and the plant material extract, the defined haemolytic activity of the reference material of saponin, and the experimental method. In order to obtain reliable results, it is essential to standardize the experimental conditions, and especially to determine the haemolytic activity by comparison with that of saponin R.

### **Recommended procedure**

To prepare the erythrocyte suspension fill a glass-stoppered flask to one-tenth of its volume with sodium citrate (36.5 g/l) TS, swirling to ensure that the inside of the flask is thoroughly moistened. Introduce a sufficient volume of blood freshly collected from a healthy ox and shake immediately. Citrated blood prepared in this way can be stored for about 8 days at 2-4°C. Place 1 ml of citrated blood in a 50-ml volumetric flask with phosphate buffer pH 7.4 TS and carefully dilute to volume. This diluted blood suspension (2% solution) can be used as long as the supernatant fluid remains clear and colourless. It must be stored at a cool temperature.

To prepare the reference solution, transfer about 10 mg of saponin R, accurately weighed, to a volumetric flask and add sufficient phosphate buffer pH 7.4 TS to make 100ml. This solution should be freshly prepared.

The extract of plant material and dilutions should be prepared as specified in the test procedure for the plant material concerned, using phosphate buffer pH 7.4 TS.

Table 3

**Determination of haemolytic activity: serial dilution for the preliminary test**

	Tube no.			
	1	2	3	4
Plant material extract (ml)	0.10	0.20	0.50	1.00
Phosphate buffer pH 7.4 TS (ml)	0.90	0.80	0.50	-
Blood suspension (2%) (ml)	1.00	1.00	1.00	1.00

**Preliminary test**

Prepare a serial dilution of the plant material extract with phosphate buffer pH 7.4 TS and blood suspension (2%) using four test-tubes as shown in Table 3.

As soon as the tubes have been prepared, gently invert them to mix, avoiding the formation of foam. Shake again after a 30-minute interval and allow to stand for 6 hours at room temperature. Examine the tubes and record the dilution at which total haemolysis has occurred, indicated by a clear, red solution without any deposit of erythrocytes. Proceed as follows.

- If total haemolysis is observed only in tube no. 4, use the original plant material extract directly for the main test.
- If total haemolysis is observed in tubes 3 and 4, prepare a two-fold dilution of the original plant material extract with phosphate buffer pH 7.4 TS.
- If total haemolysis is observed in tubes 2, 3 and 4, prepare a five-fold dilution of the original plant material extract with phosphate buffer pH 7.4 TS.
- If, after 6 hours, all four tubes contain a clear, red solution, prepare a ten-fold dilution of the original plant material extract with phosphate buffer pH 7.4 TS and carry out the preliminary test again as described above.
- If total haemolysis is not observed in any of the tubes, repeat the preliminary test using a more concentrated plant material extract.

**Main test**

Prepare a serial dilution of the plant material extract, undiluted or diluted as determined by the preliminary test, with phosphate buffer pH 7.4 TS and blood suspension (2%) using 13 test-tubes as shown in Table 4.

Carry out the dilutions and evaluations as in the preliminary test but observe the results after 24 hours. Calculate the amount of medicinal plant material in g, or of the preparation in g or ml, that produces total haemolysis.

To eliminate the effect of individual variations in resistance of the erythrocyte suspension to saponin solutions, prepare a series of dilutions of saponin R in the same manner as described above for the plant material extract. Calculate the quantity of saponin R in g that produces total haemolysis.



Table 4  
**Determination of haemolytic activity: serial dilution for the main test**

	Tube no.												
	1	2	3	4	5	6	7	8	9	10	11	12	13
Plant material extract (diluted if necessary) (ml)	0.40	0.45	0.50	0.55	0.60	0.65	0.70	0.75	0.80	0.85	0.90	0.95	1.00
Phosphate buffer pH 7.4 TS (ml)	0.60	0.55	0.50	0.45	0.40	0.35	0.30	0.25	0.20	0.15	0.10	0.05	
Blood suspension (2%) (ml)	1.00	1.00	1.00	1.00	1.00	1.00	1.00	1.00	1.00	1.00	1.00	1.00	1.00

Calculate the haemolytic activity of the medicinal plant material using the following formula:

$$1000 \times \frac{a}{b}$$

where 1000 = the defined haemolytic activity of saponin R in relation to ox blood,

$a$  = quantity of saponin R that produces total haemolysis (g),

$b$  = quantity of plant material that produces total haemolysis (g).

### 13. Determination of tannins

Tannins (or tanning substances) are substances capable of turning animal hides into leather by binding proteins to form water-insoluble substances that are resistant to proteolytic enzymes. This process, when applied to living tissue, is known as an "astringent" action and is the reason for the therapeutic application of tannins.

Chemically, tannins are complex substances; they usually occur as mixtures of polyphenols that are difficult to separate and crystallize. They are easily oxidized and polymerized in solution; if this happens they lose much of their astringent effect and are therefore of little therapeutic value.

#### Recommended procedure

To prepare the plant material extract, introduce the quantity specified in the test procedure for the plant material concerned, previously powdered to a known fineness and weighed accurately, into a conical flask. Add 150ml of water and heat over a boiling water-bath for 30 minutes. Cool, transfer the mixture to a 250-ml volumetric flask and dilute to volume with water. Allow the solid material to settle and filter the liquid through a filter-paper, diameter 12cm, discarding the first 50ml of the filtrate.

To determine the total amount of material that is extractable into water, evaporate 50.0ml of the plant material extract to dryness, dry the residue in an oven at 105°C for 4 hours and weigh ( $T_1$ ).

To determine the amount of plant material not bound to hide powder that is extractable into water, take 80.0ml of the plant material extract, add 6.0g of hide powder R and shake well for 60 minutes. Filter and evaporate 50.0 ml of the clear filtrate to dryness. Dry the residue in an oven at 105°C and weigh ( $T_2$ ).

To determine the solubility of hide powder, take 6.0g of hide powder R, add 80.0 ml of water and shake well for 60 minutes. Filter and evaporate 50.0 ml of the clear filtrate to dryness. Dry the residue in an oven at 105°C and weigh ( $T_0$ ). Calculate the quantity of tannins as a percentage using the following formula:

$$\frac{[T_1 - (T_2 - T_0)] \times 500}{w}$$

where  $w$  = the weight of the plant material in grams.

## **14. Determination of swelling index**

Many medicinal plant materials are of specific therapeutic or pharmaceutical utility because of their swelling properties, especially gums and those containing an appreciable amount of mucilage, pectin or hemicellulose.

The swelling index is the volume in ml taken up by the swelling of 1 g of plant material under specified conditions. Its determination is based on the addition of water or a swelling agent as specified in the test procedure for each individual plant material (either whole, cut or pulverized). Using a glass-stoppered measuring cylinder, the material is shaken repeatedly for 1 hour and then allowed to stand for a required period of time. The volume of the mixture (in ml) is then read.

The mixing of whole plant material with the swelling agent is easy to achieve, but cut or pulverized material requires vigorous shaking at specified intervals to ensure even distribution of the material in the swelling agent.

### **Recommended procedure**

Carry out simultaneously no fewer than three determinations for any given material. Introduce the specified quantity of the plant material concerned, previously reduced to the required fineness and accurately weighed, into a 25-ml glass-stoppered measuring cylinder. The internal diameter of the cylinder should be about 16mm, the length of the graduated portion about 125 mm, marked in 0.2-ml divisions from 0 to 25 ml in an upwards direction. Unless otherwise indicated in the test procedure, add 25 ml of water and shake the mixture thoroughly every 10 minutes for 1 hour. Allow to stand for 3 hours at room temperature, or as specified. Measure the volume in ml occupied by the plant material, including any sticky mucilage. Calculate the mean value of the individual determinations, related to 1 g of plant material.

## 15. Determination of foaming index

Many medicinal plant materials contain saponins that can cause a persistent foam when an aqueous decoction is shaken. The foaming ability of an aqueous decoction of plant materials and their extracts is measured in terms of a foaming index.

### Recommended procedure

Reduce about 1 g of the plant material to a coarse powder (sieve size no. 1250), weigh accurately and transfer to a 500-ml conical flask containing 100ml of boiling water. Maintain at moderate boiling for 30 minutes. Cool and filter into a 100-ml volumetric flask and add sufficient water through the filter to dilute to volume.

Pour the decoction into 10 stoppered test-tubes (height 16cm, diameter 16mm) in successive portions of 1 ml, 2 ml, 3 ml, etc. up to 10 ml, and adjust the volume of the liquid in each tube with water to 10ml. Stopper the tubes and shake them in a lengthwise motion for 15 seconds, two shakes per second. Allow to stand for 15 minutes and measure the height of the foam. The results are assessed as follows.

- If the height of the foam in every tube is less than 1 cm, the foaming index is less than 100.
- If a height of foam of 1 cm is measured in any tube, the volume of the plant material decoction in this tube (*a*) is used to determine the index. If this tube is the first or second tube in a series, prepare an intermediate dilution in a similar manner to obtain a more precise result.
- If the height of the foam is more than 1 cm in every tube, the foaming index is over 1000. In this case repeat the determination using a new series of dilutions of the decoction in order to obtain a result.

Calculate the foaming index using the following formula:

$$\frac{1000}{a}$$

where *a* = the volume in ml of the decoction used for preparing the dilution in the tube where foaming to a height of 1 cm is observed.

## 16. Determination of pesticide residues

Medicinal plant materials are liable to contain pesticide residues which accumulate from agricultural practices, such as spraying, treatment of soils during cultivation, and administration of fumigants during storage. It is therefore recommended that every country producing medicinal plant materials (naturally grown or cultivated) should have at least one control laboratory capable of performing the determination of pesticides in accordance with the procedure outlined below.

Since many medicinal preparations of plant origin are taken over long periods of time, limits for pesticide residues should be established following the recommendations of the Food and Agriculture Organization of the United Nations (FAO) and the World Health Organization (WHO) which have already been established for food and animal feed (9). These recommendations include the analytical methodology for the assessment of specific pesticide residues.

### Classification of pesticides

Different classifications of pesticides exist (10, 11). A classification based on the chemical composition or structure of the pesticide is most useful for analytical chemists, for example:

- chlorinated hydrocarbons and related pesticides: aldrin, HCH (hexachlorocyclohexane or benzene hexachloride, BHC), hexachlorobenzene (HCB), chlordane, DDT (dichlorodiphenylethane), dieldrin, endrin, heptachlor, lindane, methoxychlor, camphechlor (toxaphene);
- chlorinated phenoxyalkanoic acid herbicides: 2,4-D; 2,4,5-T;
- organophosphorus pesticides: carbophenothion (carbofenotion), coumaphos (coumafos), demeton, dichlorvos, dimethoate, ethion, fenclorophos (fenclofos), malathion, methyl parathion, parathion;
- carbamate insecticides: carbaryl (carbaril);
- dithiocarbamate fungicides: ferbam, maneb, nabam, thiram, zineb, ziram;
- inorganic pesticides: aluminium phosphide, calcium arsenate, lead arsenate;
- miscellaneous: bromopropylate, chloropicrin, ethylene dibromide, ethylene oxide, methyl bromide;
- pesticides of plant origin: tobacco leaf and nicotine; pyrethrum flower, pyrethrum extract and pyrethroids; derris root and rotenoids.

Only the chlorinated hydrocarbons and related pesticides (e.g. aldrin, chlordane, DDT, dieldrin, HCH) and a few organophosphorus pesticides (e.g. carbophenothion) have a long residual action. Most other pesticides have very short residual actions. Therefore it is suggested that, where the length of exposure to pesticides is unknown, the medicinal plant material should be tested for the presence of organically bound chlorine and phosphorus, or the content of these two substances should be determined. Alternative classifications of pesticides may be based on their intended use, for example:

- insecticides;
- fungicides and nematocides;

- herbicides;
- other pesticides (e.g. acaricides, molluscicides, rodenticides);
- fumigants (e.g. ethylene oxide, ethylene chlorohydrin, methyl bromide).

### **Methods for the determination of pesticide residues**

Chromatography (mostly column and gas) is recommended as the principal method for the determination of pesticide residues. Samples are extracted by a standard procedure, impurities are removed by partition and/or adsorption, and the presence of a moderately broad spectrum of pesticides is measured in a single determination. However, these techniques are not universally applicable. Some pesticides are satisfactorily carried through the extraction and clean-up procedures, others are recovered with a poor yield, and some are lost entirely. In chromatography, the separations may not always be complete, pesticides may decompose or metabolize, and many of the metabolic products are still unknown. Consequently, as a result of limitations in the analytical technique and incomplete knowledge of pesticide interaction with the environment, it is not yet possible to apply an integrated set of methods that will be satisfactory in all situations.

It is therefore desirable to test plant materials of unknown history for broad groups of compounds rather than for individual pesticides. A variety of methods meet these requirements. Chlorinated hydrocarbons and other pesticides containing chlorine in the molecule, for example, can be detected by the measurement of total organic chlorine; insecticides containing phosphate can be measured by analysis for total organic phosphorus, while pesticides containing arsenic and lead can be detected by measurement of total arsenic or total lead, respectively. Similarly, the measurement of total bound carbon disulfide in a sample will provide information on whether residues of the dithiocarbamate family of fungicides are present.

If the pesticide to which the plant material has been exposed is known or can be identified by suitable means, an established method for the determination of that particular pesticide residue should be employed.

### **General aspects of analytical methodology**

The samples should be tested as quickly as possible after collection, before any physical or chemical changes occur. If prolonged storage is envisaged, the samples should preferably be stored in air-tight containers under refrigeration.

Light can cause degradation of many pesticides, and it is therefore advisable to protect the samples and any extracts or solutions from undue exposure.

The type of container or wrapping material used should not interfere with the sample or affect the analytical results.

Solvents and reagents used in the analytical method should be free from substances that may interfere with the reaction, alter the results or provoke degradation of the pesticide residue in the sample. It is usually necessary to employ specially purified solvents or to distil them freshly in an all-glass

apparatus. Blank determinations with the solvents should be carried out, concentrating and testing them as specified in the test procedure for the plant material concerned.

The simplest and quickest procedure should be used to separate unwanted material from the sample (clean-up procedure) in order to save time when many samples have to be tested.

The process of concentrating solutions should be undertaken with great care, especially during the evaporation of the last traces of solvent, in order to avoid losses of pesticide residues. For this reason, it is often not advisable to remove the last traces of solvent. Agents, such as mineral oil or other oils of low volatility, that may help to preserve the solution could be added to retard the loss of the relatively volatile pesticides, especially when the last traces of solvent are being evaporated. However, these agents, while satisfactory in colorimetric procedures, are usually not desirable in gas chromatographic methods. It may be necessary to evaporate heat-labile compounds using a rotary vacuum apparatus.

#### **Maximum limit of pesticide residues for medicinal plant materials**

The toxicological evaluation of pesticide residues in medicinal plant materials should be based on the likely intake of the material by patients. In general, the intake of residues from medicinal plant materials should account for no more than 1% of total intake from all sources, including food and drinking-water. Certain plant materials may contain extremely high levels of pesticide residues, but the levels remaining after extraction are usually much lower, because of the low solubility in water or ethanol. It is therefore important to determine the actual quantity of residues consumed in the final dosage form.

Where the nature of the pesticide to which the plant material has been exposed is unknown, it is sufficient to determine the content of total chlorine and to base the calculation on the acceptable residue level (ARL) of the most toxic chlorine-containing pesticide (e.g. aldrin or dieldrin).

An ARL (in mg of pesticide per kg of plant material) can be calculated on the basis of the maximum acceptable daily intake of the pesticide for humans (ADI), as recommended by FAO and WHO, and the mean daily intake (MDI) of the medicinal plant material.

Some countries have established national requirements for residue limits in plant materials. Where such requirements do not exist, the following formula may be used:

$$ARL = \frac{ADI \times E \times 60}{MDI \times 100}$$

where ADI = maximum acceptable daily intake of pesticide (mg/kg of body weight);

E = extraction factor, which determines the transition rate of the pesticide from the plant material into the dosage form;

MDI = mean daily intake of medicinal plant product.

The 60 in the numerator represents mean adult body weight, while the denominator incorporates a consumption factor of 100 reflecting the fact that no more than 1% of the total pesticide residue consumed should be derived from medicinal plant material.

This formula is based on the acceptable daily intake (ADI) determined by FAO and WHO.

### **Determination of total chlorine and phosphorus**

Most pesticides contain organically bound chlorine or phosphorus.

### **Recommended procedure**

#### **Preparation of samples**

Reduce the plant material to a fine powder, and extract with a mixture of water and acetonitrile R. Most pesticides are soluble in this mixture, while most cellular constituents (e.g. cellulose, proteins, amino acids, starch, fats and related compounds) are sparingly soluble and are thus removed. A number of polar and moderately polar compounds may also be dissolved; it is therefore necessary to transfer the pesticides to light petroleum R. For pesticides containing chlorine, further purification is seldom required, but for those containing phosphorus, further purification by column chromatography may be necessary, eluting with mixtures of light petroleum R and ether R.

#### **Preparation of the column**

Use Florisil R grade 60/100 PR (or equivalent), activated at 650°C, as the support. If this material is obtained in bulk, transfer it immediately after opening to a 500-ml glass jar or bottle with a glass stopper or foil-lined, screw-top lid. Store in the dark. Before use, heat at not less than 130°C, cool in a desiccator to room temperature and heat once again to 130°C after 2 days.

Prepare a Florisil column (external diameter, 22 mm) which contains, after settling, 10 cm of activated Florisil topped with about 1 cm of anhydrous sodium sulfate R. Pre-wet the column with 40-50 ml of light petroleum R. Place a graduated flask under the column to receive the eluate.

### **Method**

Grind the material to pass through a sieve no. 710 or 840 and mix thoroughly. Place 20-50 g of the ground sample into a blender, add 350 ml of acetonitrile R with a water content of 35% (to 350 ml of water add sufficient acetonitrile R to produce 1000 ml). Blend for 5 minutes at a high speed. Filter under vacuum



through an appropriate funnel, diameter 12 cm, fitted with filter-paper, into a 500-ml suction flask.

Transfer the filtrate to a 250-ml measuring cylinder and record the volume. Transfer the measured filtrate to a 1-litre separating funnel and carefully add 100ml of light petroleum R. Shake vigorously for 1-2 minutes, add 10 ml of sodium chloride (400 g/l) TS and 600 ml of water. Hold the separating funnel in a horizontal position and mix vigorously for 30-45 seconds. Allow to separate, discard the aqueous layer and gently wash the solvent layer with two 100-ml portions of water. Discard the washings, transfer the solvent layer to a 100-ml glass-stoppered cylinder, and record the volume. Add about 15 g of anhydrous sodium sulfate R and shake vigorously. The extract must not remain in contact with this reagent for longer than 1 hour. Transfer the extract directly to a Florisil column; if necessary, reduce the volume first to 5-10 ml. Allow it to pass through the column at a rate of not more than 5 ml per minute. Carefully rinse the cylinder with two portions, each of 5 ml, of light petroleum R, transfer them to the column, rinse with further small portions of light petroleum R if necessary, and then elute at the same rate with 200 ml of ether/light petroleum TS1. Change the receiver and elute with 200 ml of ether/light petroleum TS2. Again change the receiver and elute with 200 ml of ether/light petroleum TS3. Evaporate each eluate to a suitable volume, as required, for further testing.

- The first eluate contains chlorinated pesticides (aldrin, DDE, TDE (DDD), o,p'- and p,p'-DDT, HCH, heptachlor, heptachlor epoxide, lindane, methoxychlor), polychlorinated biphenyls (PCB), and phosphated pesticides (carbophenothion, ethion, and fenchlorphos).
- The second eluate contains chlorinated pesticides (dieldrin and endrin) and phosphated pesticides (methyl parathion and parathion).
- The third eluate contains phosphated pesticide (malathion).

### **Combustion of the organic matter**

Combustion of the organic matter in oxygen is the preparatory step for the determination of chlorine and phosphorus. The pesticide is extracted from the sample and purified, if necessary. The extract is concentrated, evaporated to dryness, transferred to a sample holder, and burned in a suitable conical flask flushed with oxygen. The gases produced during combustion are then absorbed in a suitable solution. The absorbed chlorine is determined as chloride and the absorbed phosphorus as orthophosphate, both colorimetrically.

### *Apparatus*

The combustion is carried out in a 1-litre conical flask made of borosilicate glass, into the stopper of which is fused one end of a piece of platinum wire about 1 mm in diameter. To the free end of the wire is attached a piece of platinum gauze measuring about 1.5 × 2 cm to provide a means of holding the sample clear of the absorbing liquid during combustion.

*Sample holder for chlorine-containing residues.* For a small quantity of solid material, use a sample holder made from a piece of halide-free filter-paper about 5 cm long and 3 cm wide; for a small volume of liquid, preferably use a sample

holder in the form of a cone made from cellulose acetate film. Prepare the cone as follows: wearing cloth gloves and using a suitable cardboard template cut the film in a circle of 4 cm radius.

Manually pin the two edges together to form a cone. Seal the joined edges using heat to form a seam about 5 mm wide. Immerse the seam in acetone R to about one half of its width for 10 seconds. Remove and dry it immediately in a stream of hot air. Using forceps, wash the cone by dipping in a 1-litre beaker containing warm sodium hydroxide (~240 g/l) TS for 10 seconds at a temperature of about 60°C. Rinse the cone thoroughly with water and allow to drain dry on a piece of aluminium foil. Place each cone in a clean funnel (diameter 65 mm).

*Sample holder for phosphorus-containing residues.* Use a piece of halide-free filter-paper about 4 cm square as the sample holder.

*Combustion of chlorine-containing residues*

Transfer an aliquot of the extract as prepared above onto the sample holder which is placed in a funnel using a solvent that will not dissolve the sample holder. Allow the solvent to evaporate. Wearing rubber gloves, remove the sample holder and its dry contents from the funnel, and fold it over and up to form a small packet, about 1 cm<sup>2</sup> in area, and secure it in the centre of the platinum gauze. Insert a narrow strip of filter-paper, about 1 x 3 cm, as a fuse into the top of the holder, between the folds of the packet. Add 30 ml of water to the combustion flask. Moisten the neck of the flask with water. Fill the flask thoroughly with oxygen by means of a tube with its end just above the liquid. Ignite the free end of the paper strip and immediately insert the stopper. Hold the stopper firmly in place. When vigorous burning has begun, tilt the flask to prevent incompletely burned material from falling into the liquid. Immediately after combustion is completed, shake the flask vigorously for 10 minutes to dissolve the combustion products. Place a small quantity of water around the rim of the flask, and carefully withdraw the stopper. Rinse the stopper, platinum wire, platinum gauze and sides of the flask with water. Transfer the liquid and liquids used for rinsing to a 50-ml volumetric flask and dilute to volume with water.

*Combustion of phosphorus-containing residues*

Dip the sample holder made from filter-paper into methanolic sodium hydroxide TS, then suspend it in a current of heated air. Immediately transfer about 0.2 ml of an aliquot of the extract as prepared above to the sample holder with the aid of 0.2-ml portions of chloroform R using a micropipette. Allow the solvent to evaporate from the paper, fold it to form a small packet about 1 cm<sup>2</sup> in area and place it in the centre of the platinum gauze. Insert a strip of filter-paper, about 1 x 3 cm, as a fuse into the top of the holder, between the folds of the packet. Add 10 ml of sulfuric acid (~37 g/l) TS to the combustion flask and continue with the combustion as described above. Transfer the solution and the liquid used for rinsing to a 25-ml volumetric flask and dilute to volume with water.

## Determination of chlorides

### Apparatus

The determination is made with a spectrophotometer capable of measuring absorbance at 460 nm using absorption cells with path-lengths of 2 cm and 10 cm.

### Method

Place 15 ml of the solution obtained after combustion in a 50-ml conical flask together with 1 ml of ferric ammonium sulfate (0.25 mol/l) VS and 3 ml of mercuric thiocyanate TS. Swirl the contents of the flask and allow to stand for 10 minutes. Transfer a portion of the solution to a 2-cm cell and measure the absorbance at 460 nm using water in the reference cell. The reading should be made promptly to minimize absorption of chloride from the air.

Prepare a standard solution of sodium chloride R containing 5 µg of chloride per ml. Transfer aliquots of this solution (0 ml, 2 ml, 4 ml, 6 ml, 8 ml, and 10 ml) into a series of 50-ml conical flasks and dilute to 15 ml with water. Develop the colour and measure the absorbances as described above. Plot the absorbances against the chloride content of the dilutions in µg per ml and interpolate the chloride content of the solutions of the material tested.

## Determination of phosphates

The phosphomolybdate method is based on the reaction of phosphate ions with ammonium molybdate to form a molybdophosphate complex, which is subsequently reduced to form a strongly blue-coloured molybdenum complex. The intensity of the blue colour is measured spectrophotometrically. This method is applicable for the determination of any phosphates that have undergone a prior separation procedure.

Naturally occurring phosphates are present in most samples, and are often not removed during the clean-up procedure. In order to obtain background values, therefore, it is necessary to proceed with the determination for all samples, even those with no phosphate-containing pesticides. These background values should be subtracted from the results obtained on testing pesticide residues. Extracts of most uncontaminated materials contain about 0.05-0.1 mg/kg of phosphorus. Therefore, no contamination with organophosphate pesticides can be assumed for results in this range.

### Apparatus

The determination is made with a spectrophotometer capable of measuring absorbance at 820 nm using an absorption cell with a path-length of 1 cm.

### Method

Place 7 ml of the solution obtained after combustion in a calibrated 10-ml test-tube. Add 2.2 ml of sulfuric acid (300 g/l) TS and mix the solution well. Add 0.4 ml of ammonium molybdate (40 g/l) TS and swirl the mixture. Then add 0.4 ml of aminonaphtholsulfonic acid TS and swirl again. Heat the solution to 100°C for

12 minutes ( $\pm 2$  minutes), cool, and transfer a portion to a 1-cm cell. Measure the absorbance at 820 nm using water in the reference cell.

Prepare standard dilutions with a known content of phosphate and measure the absorbance as described above. Plot the absorbances against the phosphate content of the dilutions in  $\mu\text{g}$  per ml and interpolate the phosphate content of the solutions of the material tested.

## **Qualitative and quantitative determination of organochlorine pesticides**

### **Recommended procedure**

#### **Preparation of sample**

Place 20 g of powdered plant material (sieve no. 180), accurately weighed, in a 500-ml beaker (tall form), mix with 98 ml of water and allow to macerate for at least 30 minutes. Add 200 ml of acetone R; the resulting volume of extraction solvent will be 295 ml. Extract for 5 minutes, while cooling and using a high-speed mixer. Filter the homogenized mixture through a porcelain filter (Büchner funnel, diameter 70mm) fitted with a filter-paper, using a slight vacuum, into a 250-ml graduated cylinder, allowing the process to last no longer than 1 minute, and then measure the volume ( $V$ ) of the filtrate in ml.

#### **Method**

Transfer the filtrate prepared as above to a 500-ml separating funnel. Add a quantity of sodium chloride R equivalent in grams to one-tenth of the volume of the filtrate, then add 100 ml of dichloromethane R. Shake vigorously for 5 minutes, allow the phases to separate and discard the lower (aqueous) layer. Dry the acetone-dichloromethane phase, transfer it to a 500-ml conical flask, add 25 g of anhydrous sodium sulfate R and swirl occasionally. Next, filter the solution into a 500-ml flask with a ground-glass stopper using a glass funnel (diameter 100 mm) containing purified glass-wool and anhydrous sodium sulfate R. Rinse the separating funnel, the conical flask and the glass funnel twice with 10 ml of ethyl acetate R. Add 5 ml of 2,2,4-trimethylpentane R, and concentrate the crude extract to about 2 ml in a rotary vacuum evaporator in a water-bath at 30-40°C. Expel the remaining solvent in a gentle stream of air.

To purify by gel chromatography, macerate 50g of suitable beads (e.g. S-X3 bio-beads) in an elution mixture of cyclohexane R and ethyl acetate R (1:1) and pour them into a chromatographic column (length 600 mm, diameter 25 mm) adapted for use with a vacuum pump. Rinse the gel bed with the elution mixture under air-free conditions. Dissolve the extract in the flask with 5.0 ml of ethyl acetate R. Add 2 g of anhydrous sodium sulfate R, swirl gently and add 5.0 ml of cyclohexane R. Filter the completely dissolved crude extract through a rapid filter into a 10-ml test-tube with a ground-glass stopper and close the tube immediately. Then transfer 5.0 ml of the filtrate onto the gel column. Elute with the elution mixture at an average rate of 5.0 ml/minute. Plant material components leave the gel column first, followed by the active ingredients of pesticides. Fractionation must be determined for each column, using appropriate reference substances.

Discard the first fraction (about 100 ml) containing the impurities. Collect the organochlorine pesticides appearing in the next eluate (about 70ml) in a flask with a ground-glass stopper. Add 10ml of 2,2,4-trimethylpentane R and concentrate the solution to about 5 ml in a rotary vacuum evaporator and a water-bath at 30-40°C. Pipette another 5 ml of 2,2,4-trimethylpentane R into the flask and carefully evaporate the solution to about 1 ml (do not allow to become completely dry).

Calculate the amount of plant material in g in the purified extract using the following formula:

$$\frac{V}{590} \times \text{sample weight in g}$$

where V = volume of filtrate.

To purify further, transfer 1 g of previously deactivated silica gel for column chromatography (70-230 mesh) containing 1.5% of water, to a chromatographic column (length 25 cm, internal diameter 7 mm). Put 10 mm of anhydrous sodium sulfate R on top of the content of the column and cover with purified glass-wool. Before use rinse the column with 5 ml of hexane R. Allow the solvent to reach the surface of the column filling, then transfer quantitatively, by means of a pipette, the purified extract obtained by gel chromatography from the flask to the prepared silica gel column and rinse with 1 ml of hexane R. Set the flask aside for subsequent elutions.

Using a 10-ml volumetric flask as the receiver, elute any residues of polychlorinated biphenyls from the column with 10 ml of hexane R (eluate 0). Add 2 ml of an elution mixture composed of toluene R/hexane R (35:65) to the flask and swirl. Quantitatively transfer the solution to the column. Using another 10-ml volumetric flask as the receiver, elute the majority of the organochlorine pesticides from the silica gel column using 6 ml of the same elution mixture. Dilute the contents of the flasks to volume with the elution mixture (eluate 1).

Rinse the flask with 2 ml of toluene R and transfer it quantitatively to the column. Collect the eluate in a third 10-ml volumetric flask. Add 8 ml of toluene R to the flask, swirl and transfer the solution to the silica gel column; elute the remaining organochlorine pesticides using the same receiver. Dilute the contents of the flask to volume with toluene R (eluate 2).

Evaluate the test solutions by capillary gas chromatography using an electron capture detector (ECD). Confirm the findings obtained for the main column (first separation system) with a second capillary column of different polarity (second separation system).

### Determination by gas chromatography

A capillary gas chromatograph with an ECD is used for the measurement. Helium R is used as the carrier gas and a mixture of argon R and methane R (95:5) as an auxiliary gas for the detection.

#### *First separation system*

Use a vitreous silica column, 30 m long with an internal diameter of 0.25 mm, packed with a chemically bound phase of 5% phenyl, 95% methyl-polysiloxane. Use the following temperature programme:

- heat at 60°C for 0.5 minutes;
- increase the temperature at a rate of 30°C per minute to 160°C and maintain this temperature for 2 minutes;
- increase the temperature at a rate of 2°C per minute to 250°C and maintain this temperature for 5 minutes.

Use a "split/split-free" injector to inject the sample solution and maintain the injection port at a temperature of 240°C. Inject a volume of 1 µl at a rate of 30 seconds ("split-free"). The detector temperature should be 300°C.

#### *Second separation system*

Use a vitreous silica column, 15 m long with an internal diameter of 0.25 mm, packed with a chemically bound phase of 7% cyanopropyl, 7% phenyl, 86% methyl-polysiloxane. Use the following temperature programme:

- heat at 60°C for 0.2 minutes;
- increase the temperature at a rate of 30°C per minute to 180°C and maintain this temperature for 1 minute;
- increase the temperature at a rate of 2°C per minute to 250°C and maintain this temperature for 5 minutes.

Use an on-column injector to inject a volume of 1 µl of the sample solution. The detector temperature should be 300°C.

Use the "external standard" method for the qualitative and quantitative evaluation of the organochlorine pesticides in the test solutions with reference solutions of the following pesticides: α-, β-, γ- and δ-hexachlorocyclohexane (HCH); hexachlorobenzene; quintozene; aldrin; dieldrin; endrin; α- and β-endosulfan; endosulfan sulfate; heptachlor, heptachlorepoxyde; camphechlor; TDE, DDE and DDT (both *o,p'*- and *p,p'*-isomers); methoxychlor.

Measure the peak height of the pesticides obtained in the chromatograms and calculate the concentration of the residues in mg/kg using the following formula:

$$\frac{h_t \times 10}{w} \times \frac{w_r}{h_r}$$

where  $h_t$  = peak height obtained for the test solution in mm,  
 $w$  = quantity of sample in the purified extract (g),  
 $w_r$  = quantity of pesticide in ng in the reference solution injected,  
 $h_r$  = peak height obtained for the reference solution in mm.

### **Analysis of esters of organophosphorus compounds**

The extraction and the clean-up procedures can be performed as described above, but the detection requires a phosphorus flame ionization detector (P-FID).

### **Determination of specific pesticide residues in plant material**

#### **General recommendations**

For the total determination, mix thoroughly 1 kg of plant material.

In order to obtain reliable chromatographic results, do one or more of the following:

- repeat the separation using another column;
- use a different separation system;
- use a different detector system;
- apply a coupling technique;
- prepare a derivative;
- perform chromatography with a mixture of the sample and a reference substance;
- change the sample preparation;
- use a fractionated elution during the column-chromatography clean-up procedure of the plant extract and test every fraction by chromatography; and
- compare the distribution coefficient of the material with that of a reference substance.

Prior to the quantitative determination of the material to be tested, check whether there is a linear relationship between the values obtained for the reference substance and its concentration over the range 0.1-2 times the standard concentration. Otherwise, prepare another concentration range or evaluate the results using a reference curve. Use any suitable mechanical or manual technique for the chromatographic determination.

Store the reference solutions protected from light to prevent decomposition. Use glass vessels closed with glass stoppers and keep them in a container saturated with the solvent employed to avoid any increase in concentration due to evaporation. Check the loss by evaporation by interim weighing of the vessels.

Use concentrated reference solutions within 6 months and diluted reference solutions within 4 weeks.

### **Rate of recovery**

The rate of recovery (R) is the percentage of the reference material, originally added to the plant material, that is determined using the method described below.

### **Determination of desmetryn, prometryn, and simazine residues**

#### **Preparation of the plant material extract**

Place 10.0 g of powdered plant material in a 500-ml conical flask and add 125.0 ml of chloroform R. Shake the mixture for 60 minutes and filter under reduced pressure through a filter-paper (medium grade) into a round-bottomed flask. Wash the residue with 3 successive volumes each of 25.0 ml of chloroform R.

#### **Method**

Concentrate the combined filtrates to a volume of 3-5 ml using a rotary vacuum evaporator and a water-bath at 40°C. Transfer the extract to a chromatographic column as prepared below, rinsing the round-bottomed flask twice with 5.0 ml of chloroform R.

#### *Preparation of chromatographic column*

Use a glass tube (internal diameter 20-22 mm) with a restricted orifice and protected with a sintered-glass plate (e.g. P10 or P16, glass filter G4; or P40, glass filter G3). Fill the column with chloroform R, then pour purified aluminium oxide R into it to form a 100-mm thick layer. The support material should remain covered with chloroform R. After transferring the extract and the rinsing liquids to the column, elute with 150.0 ml of chloroform R, at a rate of 1-2 drops per second, collecting the eluate in a round-bottomed flask. The first purifying process is completed when no further eluate drips from the column.

Evaporate the eluate to dryness using a rotary vacuum evaporator and a water-bath at 40°C. To the residue add 10.0 ml of light petroleum R and transfer the mixture to a chromatographic column containing a layer of purified aluminium oxide R, 50 mm thick, in light petroleum R. Elute the mixture with 90.0 ml of light petroleum R, using this to rinse the round-bottomed flask, at a rate of 1-2 drops per second. Discard the eluate. Dissolve any remaining residue which has not dissolved in light petroleum R in 10.0 ml of a mixture composed of 60 volumes of chloroform R and 40 volumes of light petroleum R and transfer the solution to the column. Rinse the round-bottomed flask twice more with 10.0 ml of the solvent mixture. Transfer the liquid used for rinsing to the column. Elute with 120.0 ml of the same solvent mixture, at a rate of 1-2 drops per second and collect the eluate in a round-bottomed flask. The second purifying process is completed when no further eluate drips from the column.

Evaporate the eluate to dryness using a rotary vacuum evaporator and a water-bath at 40°C. To prepare a purified extract for the determination by gas chromatography, dissolve the residue in sufficient acetone R to produce a volume of 10.0 ml. If an especially purified extract is required, proceed as described below.



To the residue add 10.0 ml of light petroleum R and 10.0 ml of dimethyl sulfoxide R. Shake the mixture and transfer it to a separating funnel. Extract the dimethyl sulfoxide layer twice with 10.0 ml of light petroleum R. Discard the petroleum ether extract. Then add 100 ml of water to the dimethyl sulfoxide layer and extract 3 times, each with 20.0 ml of chloroform R. Extract the combined chloroform extracts twice with 20.0 ml of water and evaporate them to dryness using a rotary vacuum evaporator and a water-bath at 40°C. Transfer the residue along with a mixture of 10.0 ml of light petroleum R and 10.0 ml of hydrochloric acid (1 mol/l) VS to a separating funnel and extract the mixture first with 10.0 ml and then with 5.0 ml of hydrochloric acid (1 mol/l) VS. Discard the petroleum ether layer and adjust the pH of the combined aqueous solutions to a value between 7 and 8 using sodium hydroxide (1 mol/l) VS. Extract the solution 3 times, each with 20.0 ml of chloroform R. Dry the combined chloroform extracts with anhydrous sodium sulfate R and filter into a round-bottomed flask, rinsing the funnel 3 times with 10.0-ml portions of chloroform R. Evaporate the filtrate to dryness using a rotary vacuum evaporator and a water-bath at 40°C. Dissolve the residue in sufficient acetone R to produce 10.0 ml of especially purified extract to be used for the determination by gas chromatography.

Use the extracts as indicated below for the following plant materials:

No.	Material	No.	Material
1	Flores Calendulae	10	Fructus Foeniculi
2	Flores Chamomillae	11	Herba Millefolii
3	Folia Melissaе	12	Herba Plantaginis ancelolatae
4	Folia Menthae piperitae	13	Radix Althaeae
5	Folia Salviae	14	Radix Angelicae
6	Folia Thymi	15	Radix Levistici
7	Fructus Carvi	16	Radix Petroselini
8	Fructus Coriandri	17	Radix Valerianae
9	Fructus Cynobasti		

For materials no. 1 and 2, use an especially purified extract (see page 58); for materials no. 3-17, use a purified extract (see page 58).

### Determination of the rate of recovery

Prepare five individual samples using each of the following procedures:

1. To prepare solution S<sub>2</sub>, first dissolve separately 0.040 g of each of the reference substances, desmetryl R, prometryl R and simazine R, in sufficient acetone R to produce 100.0 ml. Then place 5.0 ml of each solution into a 100-ml volumetric flask and dilute the mixture to volume with acetone R (S<sub>2</sub>). Place 10.0 g of powdered plant material into a 500-ml conical flask and add 1.0 ml of solution S<sub>2</sub>. Shake this mixture

mechanically for 60 minutes; if necessary, repeat the operation manually and then proceed as described under "Preparation of the plant material extract". Use either the purified or especially purified extract for the determination by gas chromatography, as specified in the test procedure for the plant material concerned.

2. Treat 10.0 g of powdered plant material as described under "Preparation of the plant material extract". Use either the purified extract or the especially purified extract for the determination by gas chromatography, as specified in the test procedure for each individual plant material.

Calculate the rate of recovery (R) in % using the following formula:

$$\frac{2(a-b)}{c}$$

where  $a$  = average quantity in mg/kg of the 5 residues obtained using procedure 1,  
 $b$  = average quantity in mg/kg of the 5 residues obtained using procedure 2,  
 $c$  = quantity of reference substances in mg contained in solution S<sub>2</sub> during procedure 1.

The rate should be within the range 70-120%. It is specific for each drug.

#### **Determination by gas chromatography**

Perform the determination as described in Volume 1 of *The international pharmacopoeia* (5).

#### *Apparatus*

The equipment consists of:

- a glass column 1.2 m long, internal diameter 2 mm;
- a suitable stationary liquid phase;
- a suitable diatomaceous support.

Use nitrogen R as the carrier gas with a flow rate of 30.0 ml/min. The sample injection block should be maintained at 230°C, the column at 190°C and the detector, which should be nitrogen-selective, at 300°C. In addition:

- volume of sample solution to be injected: 2.0 µl;
- separation characteristics:  $h \leq 1.2 \times 10^{-3}$  for desmetryl R;  $R_s \geq 1.2$  for prometryl R and simazine R;
- relative standard deviation (precision of chromatographic system):  $s_r \leq 0.05$  for desmetryl R, prometryl R and simazine R.

#### *Method*

Chromatogram T. To determine the separation characteristics, inject solution S<sub>2</sub> (for the preparation of solution S<sub>2</sub> see "Determination of the rate of recovery" above). Chromatograms A<sub>1</sub>-A<sub>5</sub>. To determine the relative standard deviation, inject solution S<sub>2</sub> and repeat the determination 5 times.

Chromatogram S<sub>2</sub>. Inject 1.0 ml of solution S<sub>2</sub> for the determination of the rate of recovery. Dilute 1.0 ml of solution S<sub>2</sub> to 10.0 ml with acetone R and inject it for the chromatographic determination. On the chromatogram the peaks occur in the following sequence: prometryn, simazine, desmetryn.

Chromatogram P<sub>2</sub>. Inject the purified extract or the especially purified extract. Determine using an external standard:  $a = 0.0005$  To convert the values obtained to percentage by weight, multiply the concentration in mg/kg by  $10^4$ .

The total maximum permissible amount of residues due to desmetryn, prometryn and simazine is 2 mg per kg of plant material.

## **17. Determination of arsenic and heavy metals**

Contamination of medicinal plant materials with arsenic and heavy metals can be attributed to many causes including environmental pollution and traces of pesticides.

### **Limit test for arsenic**

The amount of arsenic in the medicinal plant material is estimated by matching the depth of colour with that of a standard stain.

### **Recommended procedure**

#### **Preparation of the sample by acid digestion**

Place 35-70g of coarsely ground material, accurately weighed, in a Kjeldahl flask, capacity 800-1000 ml. Add 10-25 ml of water and 25-50 ml of nitric acid (~1000 g/l) TS and then carefully add 20 ml of sulfuric acid (~1760g/l) TS. Heat cautiously so that no excessive foaming takes place. Gradually add nitric acid (~1000g/l) TS, drop by drop, until all the organic matter is destroyed. This is achieved when no further darkening of the solution is observed with continued heating, and a clear solution with copious vapours of sulfur trioxide is obtained. Cool, and add 75 ml of water and 25 ml of ammonium oxalate (25 g/l) TS. Heat again until sulfur trioxide vapours develop. Cool, transfer with the help of water to a 250-ml volumetric flask, and dilute to volume with water.

#### **Apparatus**

A suitable type of apparatus is constructed as follows. A wide-mouthed bottle of about 120-ml capacity is fitted with a rubber bung through which passes a glass tube. The latter, made from ordinary glass tubing, has a total length of about 200mm and an internal diameter of exactly 6.5 mm (external diameter about 8 mm). The lower end of the tube is drawn out to an internal diameter of about 1 mm, and there is a hole not less than 2 mm in diameter blown in the side of the tube, near the constricted part. The tube is positioned so that when the bottle contains 70ml of liquid the constricted end is above the surface of the liquid and the hole in the side is below the bottom of the bung. The upper end of the tube has a flat, ground surface at right-angles to the axis of the tube, with slightly rounded-off edges.

One of two rubber bungs (about 25 mm x 25 mm), each with a central hole of exactly 6.5 mm diameter, is fitted at the upper end of the tube. The other bung is fitted with a piece of glass tube about 3 mm long and with an internal diameter of exactly 6.5 mm and with a similar ground surface. One end of each of the tubes is flush with the larger end of the bungs, so that when these ends are held tightly together with a rubber band or a spring clip, the openings of the two tubes meet to form a true tube. Alternatively, the two bungs may be replaced by any suitable construction satisfying the conditions described in the test.

### **Method**

Moisten some cotton-wool with lead acetate (80g/l) TS, allow to dry, and lightly pack into the tube which fits into the wide-mouthed bottle to not less than 25 mm from the top. Between the flat surfaces of the tubes, place a piece of mercuric bromide paper AsR that is large enough to cover their openings (15 mm x 15 mm). The mercuric bromide paper AsR can be fitted by any other means provided that:

- the whole of the evolved gas passes through the paper;
- the portion of the paper in contact with the gas is a circle 6.5 mm in diameter; and
- the paper is protected from sunlight during the test.

Place an aliquot (25-50ml) of the solution being tested, prepared as described above, in the wide-mouthed bottle, add 1 g of potassium iodide AsR and 10g of granulated zinc AsR, and place the prepared glass tube assembly quickly in position. Allow the reaction to proceed for 40 minutes. Compare any yellow stain that is produced on the mercuric bromide paper AsR with a standard stain produced in a similar manner with a known quantity of dilute arsenic AsTS. Examine the test and standard stains without delay in daylight; the stains fade with time.

The most suitable temperature for carrying out the test is generally about 40°C but, as the rate of evolution of the gas varies somewhat with different batches of granulated zinc AsR, the temperature may have to be adjusted to obtain an even evolution of gas. The reaction may be accelerated by placing the apparatus on a warm surface, care being taken to ensure that the mercuric bromide paper AsR remains dry throughout.

Between successive tests, the tube must be washed with hydrochloric acid (~250g/l) AsTS, rinsed with water and dried.

### **Preparation of standard stain**

Add 10 ml of stannated hydrochloric acid (~250g/l) AsTS and 1 ml of dilute arsenic AsTS to 50 ml of water. The resulting solution, when treated as described in the general test, yields a stain on mercuric bromide paper AsR referred to as the standard stain (10 µg of As).

### **Limit test for cadmium and lead**

The method of determination is left to the analyst. Nevertheless, the determination must be consistent and sensitive enough to allow comparison with a reference material.

## Recommended procedure

### Apparatus

The equipment consists of a digestion vessel, consisting of a vitreous silica crucible (DIN 12904), "tall form", height 62mm, diameter 50mm, capacity 75ml, with a vitreous silica cover.

Materials used are:

- *digestion mixture*: 2 parts by weight of nitric acid (~1000g/l) TS and 1 part by weight of perchloric acid (~1170g/l) TS.
- *reference materials*: olive leaves (*Olea europaea*)<sup>1</sup> and hay powder<sup>2</sup>.

Clean scrupulously with nitric acid (~1000g/l) TS the digestion vessel and all other equipment to be used for the determination, rinse thoroughly several times with water and dry at 120°C.

### Preparation of the sample

For the wet digestion method in an open system, place 200-250mg of air-dried plant material, accurately weighed, finely cut and homogeneously mixed, into a cleaned silica crucible. Add 1.0ml of the digestion mixture, cover the crucible without exerting pressure and place it in an oven with a controlled temperature and time regulator (computer-controlled, if available).

Heat slowly to 100°C and maintain at this temperature for up to 3 hours; then heat to 120°C and maintain at this temperature for 2 hours. Raise the temperature very slowly to 240°C, avoiding losses due to possible violent reactions especially in the temperature range of 160-200°C, and maintain at this temperature for 4 hours. Dissolve the remaining dry inorganic residue in 2.5 ml of nitric acid (~1000g/l) TS and use for the determination of heavy metals.

Every sample should be tested in parallel with a blank.

### Method

The contents of lead and cadmium may be determined by inverse voltametry or by atomic absorption spectrophotometry.

The following maximum amounts in dried plant materials, which are based on the ADI values, are proposed:

- lead, 10 mg/kg;
- cadmium, 0.3 mg/kg.

---

<sup>1</sup> BCR reference material CRM No. 62 Community Bureau of Reference, obtainable from BCR, Directorate-General X11, Commission of the European Communities, 200 rue de la Loi, B-1049 Brussels, Belgium.

<sup>2</sup> Obtainable from IAEA/V-10, International Atomic Energy Agency, Analytical Quality Control Services, Laboratory Geibersdorf, P.O. Box 1'00, A-Vienna, Austria.

## 18. Determination of microorganisms

Medicinal plant materials normally carry a great number of bacteria and moulds, often originating in soil. While a large range of bacteria and fungi form the naturally occurring microflora of herbs, aerobic spore-forming bacteria frequently predominate. Current practices of harvesting, handling and production may cause additional contamination and microbial growth. The determination of *Escherichia coli* and moulds may indicate the quality of production and harvesting practices.

Methods for decontamination are restricted. For example, the use of ethylene oxide has been forbidden within countries of the European Union. Treatment with ionizing irradiation is also forbidden or requires a special registration procedure in some countries.

In addition, the presence of aflatoxins in plant material can be hazardous to health if absorbed even in very small amounts. They should therefore be determined after using a suitable clean-up procedure.

### Test for specific microorganisms

The conditions of the test for microbial contamination are designed to minimize accidental contamination of the material being examined; the precautions taken must not adversely affect any microorganisms that could be revealed.

### Recommended procedure

#### Pretreatment of the material being examined

Depending on the nature of the crude medicinal plant material, grind, dissolve, dilute, suspend or emulsify the material being examined using a suitable method and eliminate any antimicrobial properties by dilution, neutralization or filtration.

#### *Water-soluble materials*

Dissolve or dilute 10 g or 10 ml of plant material, unless otherwise specified in the test procedure for the material concerned, in lactose broth or another suitable medium proven to have no antimicrobial activity under the conditions of the test, adjust the volume to 100ml with the same medium. (Some materials may require the use of a larger volume.) If necessary, adjust the pH of the suspension to about 7.

#### *Non-fatty materials insoluble in water*

Suspend 10g or 10ml of material, unless otherwise specified in the test procedure for the material concerned, in lactose broth or another suitable medium proven to have no antimicrobial activity under the conditions of the test; dilute to 100ml with the same medium. (Some materials may require the use of a larger volume.) If necessary, divide the material being examined and homogenize the suspension mechanically. A suitable surfactant, such as a solution of polysorbate

80 R containing 1 mg per ml may be added. If necessary, adjust the pH of the suspension to about 7.

*Fatty materials*

Homogenize 10g or 10ml of material, unless otherwise specified in the test procedure for the material concerned, with 5g of polysorbate 20R or polysorbate 80R. If necessary, heat to not more than 40°C. (Occasionally, it may be necessary to heat to a temperature of up to 45°C, for the shortest possible time.) Mix carefully while maintaining the temperature in a water-bath or oven. Add 85 ml of lactose broth or another suitable medium proven to have no antimicrobial activity in the conditions of the test, heated to not more than 40°C if necessary. Maintain this temperature for the shortest time necessary until an emulsion is formed and, in any case, for not more than 30 minutes. If necessary, adjust the pH of the emulsion to about 7.

**Enterobacteriaceae and certain other Gram-negative bacteria**

*Detection of bacteria*

Homogenize the pretreated material appropriately and incubate at 30-37°C for a length of time sufficient for revivification of the bacteria but not sufficient for multiplication of the organisms (usually 2-5 hours). Shake the container, transfer 1g or 1ml of the homogenized material to 100ml of Enterobacteriaceae enrichment broth-Mossel and incubate at 35-37°C for 18-48 hours. Prepare a subculture on a plate with violet-red bile agar with glucose and lactose. Incubate at 35-37°C for 18-48 hours. The material passes the test if no growth of colonies of Gram-negative bacteria is detected on the plate.

*Quantitative evaluation*

Inoculate a suitable amount of Enterobacteriaceae enrichment broth-Mossel with quantities of homogenized material prepared as described under "Detection of bacteria" above, appropriately diluted as necessary, containing 1.0g, 0.1g and 10µg, or 1.0ml, 0.1 ml and 10µl, of the material being examined. Incubate at 35-37°C for 24-48 hours. Prepare a subculture of each of the cultures on a plate with violet-red bile agar with glucose and lactose in order to obtain selective isolation. Incubate at 35-37°C for 18-24 hours. The growth of well-developed colonies, generally red or reddish in colour, of Gram-negative bacteria constitutes a positive result. Note the smallest quantity of material that gives a positive result. Determine the probable number of bacteria using Table 5.

*Escherichia coli*

Transfer a quantity of the homogenized material in lactose broth, prepared and incubated as described above, and containing 1 g or 1 ml of the material being examined, to 100 ml of MacConkey broth and incubate at 43-45°C for 18-24 hours.



**Table 5**  
**Determination of Enterobacteriaceae and certain other Gram-negative bacteria**

Result for each quantity or volume			Probable number of bacteria per g of material
1.0 g or 1.0 ml	0.1g or 0.1 ml	0.01 g or 0.01 ml	
+	+	+	More than 10 <sup>2</sup>
+	+	–	Less than 10 <sup>2</sup> but more than 10
+	–	–	Less than 10 but more than 1
–	–	–	Less than 1

Prepare a subculture on a plate with MacConkey agar and incubate at 43-45°C for 18-24 hours. Growth of red, generally non-mucoid colonies of Gram-negative rods, sometimes surrounded by a reddish zone of precipitation, indicates the possible presence of *E. coli*. This may be confirmed by the formation of indole at 43.5-44.5°C or by other biochemical reactions. The material passes the test if no such colonies are detected or if the confirmatory biochemical reactions are negative.

***Salmonella spp.***

Incubate the solution, suspension or emulsion of the pretreated material prepared as described above at 35-37°C for 5-24 hours, as appropriate for enrichment.

*Primary test*

Transfer 10 ml of the enrichment culture to 100 ml of tetrathionate bile brilliant green broth and incubate at 42-43°C for 18-24 hours. Prepare subcultures on at least two of the following three agar media: deoxycholate citrate agar; xylose, lysine, deoxycholate agar; and brilliant green agar. Incubate at 35-37°C for 24-48 hours. Carry out the secondary test if any colonies are produced that conform to the description given in Table 6.

**Table 6**  
**Description of *Salmonella* colonies appearing on different culture media**

Medium	Description of colony
Deoxycholate citrate agar	Well developed, colourless
Xylose, lysine, deoxycholate agar	Well developed, red, with or without black centres deoxycholate agar
Brilliant green agar	Small, transparent and colourless, or opaque, pink or white (frequently surrounded by a pink to red zone)

### *Secondary test*

Prepare a subculture of any colonies showing the characteristics described in Table 6 on the surface of triple sugar iron agar using the deep inoculation technique. This can be achieved by first inoculating the inclined surface of the culture medium followed by a stab culture with the same inoculating needle and incubating at 35-37°C for 18-24 hours. The test is positive for the presence of *Salmonella* spp. if a change of colour from red to yellow is observed in the deep culture (but not in the surface culture), usually with the formation of gas with or without production of hydrogen sulfide in the agar. Confirmation is obtained by appropriate biochemical and serological tests.

The material being examined passes the test if cultures of the type described do not appear in the primary test, or if the confirmatory biochemical and serological tests in the secondary test are negative.

### *Pseudomonas aeruginosa*

Pretreat the material being examined as described on pages 64-65 but using buffered sodium chloride-peptone solution, pH 7.0, or another suitable medium shown not to have antimicrobial activity under the conditions of the test, in place of lactose broth. Inoculate 100 ml of soybean-casein digest medium with a quantity of the solution, suspension or emulsion thus obtained containing 1g or 1 ml of the material being examined. Mix and incubate at 35-37°C for 24-48 hours. Prepare a subculture on a plate of cetrinide agar and incubate at 35-37 °C for 24-48 hours. If no growth of microorganisms is detected, the material passes the test. If growth of colonies of Gram-negative rods occurs, usually with a greenish fluorescence, apply an oxidase test and test the growth in soybean-casein digest medium at 42°C. The following method may be used. Place 2 or 3 drops of a freshly prepared 0.01 g/ml solution of N,N,N',N'-tetramethyl-p-phenylenediamine dihydrochloride R on filter-paper and apply a smear of the suspected colony; the test is positive if a purple colour is produced within 5-10 seconds. The material passes the test if cultures of the type described do not appear or if the confirmatory biochemical test is negative.

### *Staphylococcus aureus*

Prepare an enrichment culture as described for *Pseudomonas aeruginosa*. Prepare a subculture on a suitable medium such as Baird-Parker agar. Incubate at 35-37°C for 24-48 hours. The material passes the test if no growth of microorganisms is detected. Black colonies of Gram-positive cocci often surrounded by clear zones may indicate the presence of *Staphylococcus aureus*. For catalase-positive cocci, confirmation may be obtained, for example, by coagulase and deoxyribonuclease tests. The material passes the test if cultures of the type described do not appear or if the confirmatory biochemical test is negative.

### **Validation of the tests for specific microorganisms**

If necessary, grow separately the test strains listed in Table 7 on the culture media indicated at 30-35°C for 18-24 hours. Dilute portions of each of the cultures using buffered sodium chloride-peptone solution pH 7.0 so that the test suspensions contain about  $10^3$ ; microorganisms per ml. Mix equal volumes of

each suspension and use 0.4 ml (approximately  $10^2$  microorganisms of each strain) as an inoculum in tests for *Escherichia coli*, *Salmonella spp.*, *Pseudomonas aeruginosa* and *Staphylococcus aureus*, in the presence and absence of the material being examined, if necessary. The test method should give a positive result for the respective strain of microorganism.

**Table 7**

**Test strains and culture media for use in validating the tests for specific microorganisms**

<b>Microorganism</b>	<b>Strain number<sup>a</sup></b>	<b>Medium</b>
<i>Escherichia coli</i>	e.g. NCIMB 8545 (ATCC 8739, CIP 53.126)	lactose broth
<i>Pseudomonas aeruginosa</i>	e.g. NCIMB 8626 (ATCC 9027, CIP 82.118)	soybean-casein digest medium
<i>Salmonella typhimurium</i>	No strain number is recommended. Species not pathogenic for humans, such as <i>Salmonella abony</i> (NCTC 6017, CIP 80.39), may be used	lactose broth
<i>Staphylococcus aureus</i>	e.g. NCIMB 8625 (ATCC 6538 P, CIP 53.156) or NCIMB 9518 (ATCC 6538, CIP 4.83)	soybean-casein digest medium

<sup>a</sup>See section 20, page 78.

**Total viable aerobic count**

The total viable aerobic count of the material being examined is determined, as specified in the test procedure, for the plant material concerned using one of the following methods: membrane-filtration, plate count or serial dilution.

**Pretreatment of the material being examined**

Pretreat the material as described in the "Test for specific microorganisms", page 64, but in place of lactose broth use buffered sodium chloride-peptone solution pH 7.0, or another suitable medium shown not to have antimicrobial activity under the conditions of the test.

*Membrane filtration*

Use membrane filters with a nominal pore size of not greater than 0.45  $\mu\text{m}$ , the effectiveness of which in retaining bacteria has been established. For example, cellulose nitrate filters are used for aqueous, oily and weakly alcoholic solutions, and cellulose acetate filters for strongly alcoholic solutions. The technique described uses filter discs of about 50mm in diameter. For filters of a different diameter, adjust the volumes of the dilutions and washings accordingly. Sterilize the filtration apparatus and the membrane by appropriate means. They are

designed to permit the solution being examined to be introduced and filtered under aseptic conditions, and the membrane to be transferred to the culture medium.

Transfer 10ml or a solution containing 1g of the material to each of two membrane filters and filter immediately. If necessary, dilute the pretreated material to obtain an expected colony count of 10-100. Wash each membrane, filtering three or more successive quantities of approximately 100ml of a suitable liquid such as buffered sodium chloride-peptone solution, pH 7.0. For fatty materials, a suitable surfactant may be added, such as polysorbate 20R or polysorbate 80R. Transfer one of the membrane filters, intended primarily for the enumeration of bacteria, to the surface of a plate with casein-soybean digest agar and the other, intended primarily for the enumeration of fungi, to the surface of a plate with Sabouraud glucose agar with antibiotics. Incubate the plates for 5 days, unless a more reliable count can be obtained otherwise, at 30-35°C for the detection of bacteria and at 20-25°C for the detection of fungi. Count the number of colonies formed. Calculate the number of microorganisms per g or per ml of the material tested, if necessary counting bacteria and fungi separately.

#### *Plate count*

*For bacteria.* Use Petri dishes 9-10 cm in diameter. To one dish add a mixture of 1 ml of the pretreated material and about 15 ml of liquefied casein-soybean digest agar at a temperature not exceeding 45°C. Alternatively, spread the pretreated material on the surface of the solidified medium in a Petri dish. If necessary, dilute the pretreated material as described above to obtain an expected colony count of not more than 300. Prepare at least two dishes using the same dilution and incubate them at 30-35°C for 5 days, unless a more reliable count is obtained in a shorter period of time. Count the number of colonies formed and calculate the results using the plate with the largest number of colonies, up to a maximum of 300.

*For fungi.* Use Petri dishes 9-10 cm in diameter. To one dish add a mixture of 1 ml of the pretreated material and about 15 ml of liquefied Sabouraud glucose agar with antibiotics at a temperature not exceeding 45°C. Alternatively, spread the pretreated material on the surface of the solidified medium in a Petri dish. If necessary, dilute the pretreated material as described above to obtain an expected colony count of not more than 100. Prepare at least two dishes using the same dilution and incubate them at 20-25°C for 5 days, unless a more reliable count is obtained in a shorter period of time. Count the number of colonies formed and calculate the results using the dish with not more than 100 colonies.

#### *Serial dilution*

Prepare a series of 12 tubes each containing 9-10ml of soybean-casein digest medium. To each of the first three tubes add 1 ml of the 1:10 dilution of dissolved, homogenized material prepared as described on pages 64-65. To the next three tubes add 1 ml of a 1:100 dilution of the material and to the next three tubes add 1 ml of a 1:1000 dilution of the material. To the last three tubes add 1 ml of the diluent. Incubate the tubes at 30-35°C for at least 5 days. No microbial growth

should appear in the last three tubes. If the reading of the results is difficult or uncertain owing to the nature of the material being examined, prepare a subculture in a liquid or a solid medium, and evaluate the results after a further period of incubation. Determine the most probable number of microorganisms per g or ml of the material using Table 8.

If, for the first column, the number of tubes showing microbial growth is two or less, the most probable number of microorganisms per g or per ml is less than 100.

**Effectiveness of the culture medium and validity of the counting method**

The following strains are normally used (see also section 20):

<i>Staphylococcus aureus</i>	NCIMB 8625 (ATCC 6538-P, CIP 53.156) or NCIMB 9518 (ATCC 6538, CIP 4.83)
<i>Bacillus subtilis</i>	NCIMB 8054 (ATCC 6633, CIP 52.62)
<i>Escherichia coli</i>	NCIMB 8545 (ATCC 8739, CIP 53.126)
<i>Candida albicans</i>	ATCC 2091 (CIP 1180.79) or ATCC 10 231 (NCPF 3179, CIP 48.72)

Allow the test strains to grow separately in tubes containing soybean-casein digest medium at 30-35°C for 18-24 hours, except for *Candida albicans* which needs a temperature of 20-25°C for 48 hours.

Dilute portions of each of the cultures using buffered sodium chloride-peptone solution pH 7.0 to obtain test suspensions containing about 100 viable microorganisms per ml. Use the suspension of each microorganism separately as a control of the counting methods, in the presence and absence of the material being examined, if necessary.

**Table 8**  
**Determination of total viable aerobic count**

Number of tubes 100mg or 0.1 ml per tube	with microbial 10mg or 0.01 ml per tube	growth <sup>a</sup> 1mg or 0.001 ml per tube	Most probable number of microorganisms per g or ml
3	3	3	>1100
3	3	2	1100
3	3	1	500
3	3	0	200
3	2	3	290
3	2	2	210
3	2	1	150
3	2	0	90
3	1	3	160
3	1	2	120
3	1	1	70
3	1	0	40
3	0	3	95
3	0	2	60
3	0	1	40
3	0	0	23

<sup>a</sup> Amounts in mg or ml are quantities of original plant material.

To validate the method, a count for the test organism should be obtained differing by not more than a factor of 10 from the calculated value for the inoculum. To test the sterility of the medium and the diluent, as well as aseptic performance, carry out the total viable aerobic count using sterile buffered sodium chloride-peptone solution pH 7.0 as the test preparation. There should be no growth of microorganisms.

### **Microbial contamination limits in medicinal plant materials**

Different limits are set according to the use of the material and the material itself.

- For contamination of "crude" plant material intended for further processing (including additional decontamination by a physical or chemical process) the limits, adapted from the provisional guidelines established by an international consultative group (12), are given for untreated plant material harvested under acceptable hygienic conditions:
  - *Escherichia coli*, maximum  $10^4$  per gram;
  - mould propagules, maximum  $10^5$  per gram.
- For plant materials that have been pretreated (e.g. with boiling water as used for herbal teas and infusions) or that are used as topical dosage forms:
  - aerobic bacteria, maximum  $10^7$  per gram;

- yeasts and moulds, maximum  $10^4$  per gram;
  - *Escherichia coli*, maximum  $10^2$  per gram;
  - other enterobacteria, maximum  $10^4$  per gram;
  - salmonellae, none.
- For other plant materials for internal use:
    - aerobic bacteria, maximum  $10^5$  per gram;
    - yeasts and moulds, maximum  $10^3$  per gram;
    - *Escherichia coli*, maximum 10 per gram;
    - other enterobacteria, maximum  $10^3$ , per gram;
    - salmonellae, none.

### **Test for aflatoxins**

This test is designed to detect the possible presence of aflatoxins B<sub>1</sub>, B<sub>2</sub>, G<sub>1</sub> and G<sub>2</sub>, which are highly dangerous contaminants in any material of plant origin.

### **Recommended procedure**

#### **Preparation of samples**

Grind or reduce not less than 100g of crude medicinal plant material to a moderately fine powder (sieve no. 355/180). The larger the sample size, i.e. 500g-1kg or more, the greater the possibility of detecting pockets of contamination.

Weigh 50g of the powdered material, transfer to a conical glass-stoppered flask, and add 170 ml of methanol R and 30 ml of water. Using a mechanical device, shake vigorously for not less than 30 minutes. Filter through a medium-porosity filter-paper. If a special clean-up procedure is required (see below), collect 100ml of filtrate (A) from the start of flow; otherwise discard the first 50ml and collect 40ml of filtrate (B).

In order to eliminate interfering plant pigments use a special clean-up procedure: transfer 100 ml of filtrate A to a 250-ml beaker and add 20 ml of zinc acetate/aluminium chloride TS and 80 ml of water. Stir, allow to stand for 5 minutes, add 5 g of a filter aid, such as diatomaceous earth, mix and filter through a medium-porosity filter-paper. Discard the first 50ml and collect 80ml of filtrate (C).

Transfer either filtrate B or C to a separating funnel. Add 40ml of sodium chloride (100 g/l) TS and 25 ml of light petroleum R, and shake for 1 minute. Allow the layers to separate and transfer the lower layer to a second separating funnel. Extract twice with 25 ml of dichloromethane R and shake for 1 minute. Allow the layers to separate and combine each of the lower layers in a 125-ml conical flask. Add several boiling chips and evaporate almost to dryness on a water-bath. Cool the residue, cover the flask and keep it for the determination by thin-layer chromatography or for a further clean-up procedure by column chromatography.

If necessary, remove further interfering compounds using a column 300 mm long with an internal diameter of 10 mm, a stopper and either a medium-pore sintered disc or a glass-wool plug. Prepare a slurry by mixing 2 g of silica gel R with 10 ml of a mixture of 3 volumes of ether R and 1 volume of light petroleum R, pour into the column and wash with 5 ml of the same solvent mixture. Allow the adsorbent to settle and add to the top of the column a layer of 1.5 g of anhydrous sodium sulfate R. Dissolve the residue from above in 3 ml of dichloromethane R and transfer it to the column. Rinse the flask twice with 1-ml portions of dichloromethane R and add them to the column, eluting at a rate not faster than 1 ml/min. Then add successively to the column 3 ml of light petroleum R, 3 ml of ether R and 3 ml of dichloromethane R, and elute at a rate not faster than 3 ml/min. Discard the eluates. Add to the column 6 ml of a mixture of 9 volumes of dichloromethane R and 1 volume of acetone R and elute at a rate not faster than 1 ml/min, preferably without using vacuum. Collect this eluate in a small vial, add a few boiling chips and evaporate just to dryness on a water-bath.

### **Method**

To either of the residues obtained above, add 0.2 ml of a mixture of 98 volumes of chloroform R and 2 volumes of acetonitrile R, close the vial and shake vigorously until the residues are dissolved, preferably using a vortex mixer.

Carry out the test as described in section 6, "Thin-layer chromatography", using silica gel G as the coating substance and a mixture of 85 volumes of chloroform R, 10 volumes of acetone R and 5 volumes of 2-propanol R as the mobile phase. Apply separately to the plate 2.5 µl, 5 µl, 7.5 µl and 10 µl of aflatoxin mixture TS, then apply three volumes, each of 10 µl, of the sample residues. Further superimpose on one of these spots 5 µl of aflatoxin mixture TS. Place the plate in an unsaturated chamber and develop. After removing the plate from the chromatographic chamber, allow it to dry in air and examine the chromatogram in a dark room under ultraviolet light (365 nm).

Four clearly separated blue fluorescent spots are obtained from the aflatoxin mixture. Observe any spot obtained from the solutions of the residues that coincides in hue and position with those of the aflatoxin mixture. Any spot obtained from the solutions of the residues with the superimposed aflatoxin mixture should be more intense than the corresponding spot for the test solution, and should show no sign of separation or tailing, which would be a sign of dissimilar compounds.

### **Interpretation of results**

No spots corresponding to aflatoxin should be obtained from any of the sample residues. If any such spot is obtained, compare its position with the spots obtained from the aflatoxin mixture to identify the type of aflatoxin present. An approximate estimation of the concentration of aflatoxin in the sample may be obtained by comparing the intensity of the spots with those of the aflatoxin mixtures.



## **19. Radioactive contamination**

A certain amount of exposure to ionizing radiation cannot be avoided since there are many sources, including radionuclides occurring naturally in the ground and the atmosphere. These sources are described extensively in the booklet *Facts about low-level radiation* (13).

Dangerous contamination may be the consequence of a nuclear accident. The World Health Organization, in close collaboration with several other international organizations, has developed guidelines for use in the event of widespread contamination by radionuclides resulting from a major nuclear accident (14). This publication emphasizes that the health risks from food accidentally contaminated by radionuclides depend not only on the specific radionuclide and the level of contamination but also on the quantity of food consumed.

The range of radionuclides that may be released into the environment as the result of a nuclear accident might include long-lived and short-lived fission products, actinides, and activation products. The nature and the intensity of radionuclides released may differ markedly and depend on the source (reactor, reprocessing plant, fuel fabrication plant, isotope production unit, etc.).

The amount of exposure to radiation depends on the intake of radionuclides and other variables such as age, metabolic kinetics, and weight of the individual (also known as the dose conversion factor).

Even at maximum observed levels of radioactive contamination with the more dangerous radionuclides, significant risk is associated only with consumption of quantities of over 20 kg of plant material per year so that a risk to health is most unlikely to be encountered given the amount of medicinal plant materials that would need to be ingested. Additionally, the level of contamination might be reduced during the manufacturing process. Therefore, no limits for radioactive contamination are proposed.

### **Method of measurement**

Since radionuclides from accidental discharges vary with the type of facility involved, a generalized method of measurement is so far not available. However, should such contamination be of concern, suspect samples can be analysed by a competent laboratory. Details of laboratory techniques are available from the International Atomic Energy Agency (IAEA).<sup>3</sup>

---

<sup>3</sup> International Atomic Energy Agency (IAEA), Analytical Quality Control Services, Laboratory Seibersdorf, PO Box 100, Vienna, Austria.

## 20. Culture media and strains of microorganisms

### Culture media

The following media are satisfactory, but other media may be used if they have similar nutritive and selective properties for the microorganisms to be tested.

#### **Baird-Parker agar**

*Procedure.* Dissolve 10.0 g of pancreatic digest of casein R, 5.0 g of beef extract R, 1.0g of water-soluble yeast extract R, 5.0 g of lithium chloride R, 20.0 g of agar R, 12.0 g of glycine R and 10.0 g of sodium pyruvate R in sufficient water to produce 950 ml. Heat to boiling for 1 minute, shaking frequently and adjust the pH to 6.6-7.0 using sodium hydroxide (0.5 mol/l) VS. Sterilize in an autoclave at 121°C for 15 minutes, cool to 45-50°C and add 10 ml of a sterile 0.01 g/ml solution of potassium tellurite R and 50 ml of egg-yolk emulsion.

#### **Brilliant green agar**

*Procedure.* Dissolve 10.0 g of dried peptone R (meat and casein), 3.0 g of water-soluble yeast extract R, 5.0 g of sodium chloride R, 10.0 g of lactose R, 10.0 g of sucrose R, 20.0 g of agar R, 0.08 g of phenol red R and 12.5 mg of brilliant green R in sufficient water to produce 1000 ml. Heat to boiling for 1 minute. Using sodium hydroxide (0.05 mol/l) VS adjust the pH to 6.7-7.1. Immediately before use, sterilize in an autoclave at 121°C for 15 minutes, cool to 50°C and pour into Petri dishes.

#### **Buffered sodium chloride-peptone solution pH 7.0**

*Procedure.* Dissolve 3.56 g of potassium dihydrogen phosphate R, 7.23 g of disodium hydrogen phosphate R, 4.30 g of sodium chloride R and 1.0 g of dried peptone R (meat and casein) in sufficient water to produce 1000ml. Polysorbate 20 R or polysorbate 80 R may be added, 0.001-0.01 g per ml. Sterilize in an autoclave at 121°C for 15 minutes.

#### **Casein-soybean digest agar**

*Procedure.* Dissolve 15.0g of pancreatic digest of casein R, 3.0g of papaic digest of soybean meal R, 5.0 g of sodium chloride R and 15.0 g of agar R in sufficient water to produce 1000 ml. Using sodium hydroxide (0.05 mol/l) VS adjust the pH to 7.1-7.5. Sterilize in an autoclave at 121°C for 15 minutes.

#### **Cetrimide agar**

*Procedure.* Dissolve 20.0 g of pancreatic digest of gelatin R, 1.4g of magnesium chloride R, 10.0 g of potassium sulfate R, 0.3 g of cetrimide R, 13.6 g of agar R and 10.0 ml of glycerol R in sufficient water to produce 1000 ml. Heat to boiling for 1 minute with shaking. Using sodium hydroxide (0.05 mol/l) VS adjust the pH to 7.0-7.4. Sterilize in an autoclave at 121°C for 15 minutes.

#### **Deoxycholate citrate agar**

*Procedure.* Dissolve 10.0 g of beef extract R, 10.0 g of dried peptone R (meat), 10.0 g of lactose R, 20.0 g of sodium citrate R, 1.0 g of iron(III) citrate R, 5.0 g of sodium deoxycholate, 13.5 g of agar R and 20 mg of neutral red R in sufficient

water to produce 1000 ml. Heat gently to boiling for 1 minute, cool to 50°C and adjust the pH to 7.1-7.5 using sodium hydroxide (0.05 mol/l) VS. Pour into Petri dishes. Do not heat in an autoclave.

#### **Enterobacteriaceae enrichment broth-Mossel**

*Procedure.* Dissolve 10.0g of pancreatic digest of gelatin R, 5.0g of glucose hydrate R, 20.0g of dehydrated ox bile R, 2.0g of potassium dihydrogen phosphate R, 8.0g of disodium hydrogen phosphate R and 15mg of brilliant green R in sufficient water to produce 1000ml. Heat to boiling for 30 minutes and cool immediately. Using sodium hydroxide (0.05 mol/l) VS adjust the pH to 7.0-7.4.

#### **Lactose broth**

*Procedure.* Dissolve 3.0 g of beef extract R, 5.0 g of pancreatic digest of gelatin R and 5.0 g of lactose R in sufficient water to produce 1000 ml. Using sodium hydroxide (0.05 mol/l) VS adjust the pH to 6.7-7.1. Sterilize in an autoclave at 121°C for 15 minutes.

#### **MacConkey agar**

*Procedure.* Dissolve 17.0g of pancreatic digest of gelatin R, 3.0g of dried peptone R (meat and casein), 10.0g of lactose R, 5.0g of sodium chloride R, 1.5g of bile salts R, 13.5g of agar R, 30mg of neutral red R and 1.0mg of crystal violet R in sufficient water to produce 1000ml. Using sodium hydroxide (0.05mol/l) VS adjust the pH to 6.9-7.3. Heat to boiling for 1 minute with constant shaking then sterilize in an autoclave at 121°C for 15 minutes.

#### **MacConkey broth**

*Procedure.* Dissolve 20.0 g of pancreatic digest of gelatin R, 10.0 g of lactose R, 5.0 g of dehydrated ox bile R and 10 mg of bromocresol purple R in sufficient water to produce 1000 ml. Using sodium hydroxide (0.05 mol/l) VS adjust the pH to 7.1-7.5. Sterilize in an autoclave at 121°C for 15 minutes.

#### **Sabouraud glucose agar with antibiotics**

*Procedure.* Dissolve 10.0g of dried peptone R (meat and casein), 40.0g of glucose hydrate R and 15.0g of agar R in sufficient water to produce 1000ml. Using acetic acid (~60 g/l) TS adjust the pH to 5.4-5.8. Sterilize in an autoclave at 121°C for 15 minutes. Immediately before use, add sterile solutions of 0.10g of benzylpenicillin sodium R and 0.10g of tetracycline R per litre of medium or alternatively, before sterilization, add 0.050g of chloramphenicol R per litre of medium.

#### **Soybean-casein digest medium**

*Procedure.* Dissolve 17.0g of pancreatic digest of casein R, 3.0g of papaic digest of soybean meal R, 5.0g of sodium chloride R, 2.5g of dipotassium hydrogen phosphate R and 2.5g of glucose hydrate R in sufficient water to produce 1000 ml. Using sodium hydroxide (0.05 mol/l) VS adjust the pH to 7.1-7.5. Sterilize in an autoclave at 121°C for 15 minutes.

### **Tetrathionate bile brilliant green broth**

*Procedure.* Dissolve 8.6g of dried peptone R, 8.0 g of dehydrated ox bile R, 6.4g of sodium chloride R, 20.0g of calcium carbonate RI, 20.0g of potassium tetrathionate R and 0.070g of brilliant green R in sufficient water to produce 1000 ml. Using sodium hydroxide (0.05 mol/l) VS adjust the pH to 6.8-7.2. Heat just to boiling; do not reheat.

### **Triple sugar iron agar**

*Procedure.* Dissolve 3.0 g of beef extract R, 3.0 g of water-soluble yeast extract, 20.0 g of dried peptone R (casein and beef), 5.0 g of sodium chloride R, 10.0 g of lactose R, 10.0 g of sucrose R, 1.0 g of glucose hydrate R, 0.3g of brown ammonium iron(III) citrate R, 0.3 g of sodium thiosulfate R, 25 mg of phenol red R and 12.0 g of agar R in sufficient water to produce 1000 ml. Heat to boiling for 1 minute with shaking. Using sodium hydroxide (0.05 mol/l) VS adjust the pH to 7.2-7.6. Distribute in tubes and sterilize in an autoclave at 121°C for 15 minutes. Allow to set in an inclined position covered with a butt.

### **Violet-red bile agar with glucose and lactose**

*Procedure.* Dissolve 3.0 g of water-soluble yeast extract R, 7.0 g of pancreatic digest of gelatin R, 1.5 g of bile salts R, 10.0 g of lactose R, 5.0 g of sodium chloride R, 10.0g of glucose hydrate R, 15.0 g of agar R, 30 mg of neutral red R and 2.0 mg of crystal violet R in sufficient water to produce 1000 ml. Heat to boiling and adjust the pH to 7.2-7.6 using sodium hydroxide (0.05 mol/l) VS. Do not heat in an autoclave.

### **Xylose, lysine, deoxycholate agar**

*Procedure.* Dissolve 3.5 g of xylose R, 5.0 g of L-lysine R, 7.5 g of lactose R, 7.5 g of sucrose R, 5.0 g of sodium chloride R, 3.0 g of water-soluble yeast extract R, 0.08 g of phenol red R, 13.5 g of agar R, 2.5 g of sodium deoxycholate R, 6.8 g of sodium thiosulfate R and 0.8g of brown ammonium iron(III) citrate R in sufficient water to produce 1000 ml. Using sodium hydroxide (0.05 mol/l) VS, adjust the pH to 7.2-7.6. Heat just to boiling, cool to 50°C and pour into Petri dishes. Do not heat in an autoclave.

### **Strains of microorganisms**

The strains of microorganism referred to throughout the text are suitable, but others may be used if they have similar properties. The designations of the strains and the addresses from which they may be obtained are as follows:

ATCC	American Type Culture Collection, 12301 Park Lawn Drive, Rockville, MD 20852, USA.
CIP	Collection de l'Institut Pasteur, Service de la Collection Nationale de Cultures de Microorganismes (CNCM), 25 rue du Docteur Roux, F 75015 Paris, France.
NCIMB	National Collection of Industrial and Marine Bacteria, 23 St Machar Drive, Aberdeen AB24 3RY, Scotland.

*Quality control methods for medicinal plant materials*

- NCPF National Collection of Pathogenic Fungi, PHLS Mycology Reference Laboratory, Public Health Laboratory, Kingsdown, Bristol BS2 8EL, England.
- NCTC National Collection of Type Cultures, Central Public Health Laboratory, 61 Colindale Avenue, London NW9 5HT, England.

## 21. Specifications for adsorbents for use in thin-layer chromatography

### **Cellulose**

*Description.* A fine, white, homogeneous powder with an average particle size of less than 30  $\mu\text{m}$ .

*Preparation.* Suspend 15 g in 100 ml of water and homogenize for 60 seconds in an electric mixer. Carefully coat cleaned plates with a layer 0.25 mm thick using a spreading device. Allow the coated plates to dry in air.

*Separating power.* Apply separately to the adsorbent layer 10  $\mu\text{l}$  of 0.25 mg/ml solutions containing respectively brilliant black BN R, amaranth S R, fast yellow AB R and tropaeolin O R in a mixture of equal volumes of methanol R and water. Develop the plate using a mixture of 50 volumes of 1-propanol R, 10 volumes of ethyl acetate R and 40 volumes of water over a distance of 10 cm. The chromatogram shows four clearly separated spots.

### **Cellulose, microcrystalline**

*Description.* A fine, white, homogeneous powder with an average particle size of less than 30  $\mu\text{m}$ .

*Preparation.* Suspend 25 g in 90 ml of water and homogenize for 60 seconds in an electric mixer. Carefully coat cleaned plates with a layer 0.25 mm thick using a spreading device. Allow the coated plates to dry in air.

*Separating power.* Apply separately to the adsorbent layer 10  $\mu\text{l}$  of 0.25 mg/ml solutions containing respectively brilliant black BN R, amaranth S R, fast yellow R and tropaeolin O R in a mixture of equal volumes of methanol R and water. Develop the plate using a mixture of 50 volumes of 1-propanol R, 10 volumes of ethyl acetate R and 40 volumes of water over a distance of 10cm. The chromatogram shows four clearly separated spots.

### **Cellulose F<sub>254</sub>**

*Description.* A fine, white, homogeneous powder with an average particle size of less than 30  $\mu\text{m}$  containing a fluorescent indicator with an optimal intensity at 254 nm.

*Preparation.* Suspend 25 g in 100 ml of water and homogenize for 60 seconds using an electric mixer. Carefully coat cleaned plates with a layer 0.25 mm thick using a spreading device. Allow the coated plates to dry in air.

*Separating power.* Apply separately to the adsorbent layer 10  $\mu\text{l}$  of 0.25 mg/ml solutions containing respectively brilliant black BN R, amaranth S R, fast yellow R and tropaeolin O R in a mixture of equal volumes of methanol R and water. Develop the plate using a mixture of 50 volumes of 1-propanol R, 10 volumes of ethyl acetate R and 40 volumes of water over a distance of 10cm. The chromatogram shows four clearly separated spots.

*Fluorescence.* Prepare a 1.0 mg/ml solution of benzoic acid R in a mixture of 9 volumes of 2-propanol R and 1 volume of formic acid (~1080 g/l) TS. Apply to the adsorbent layer at 10 points of application, increasing the quantities of the solution from 1  $\mu$ l to 10  $\mu$ l. Develop the chromatogram using a mixture of 9 volumes of 2-propanol R and 1 volume of formic acid (~1080 g/l) TS. Allow the solvents to evaporate and examine the chromatogram in ultraviolet light at 254 nm. The benzoic acid appears as dark spots on a fluorescent background in the upper third of the chromatogram for amounts of 2  $\mu$ g and more.

### **Kieselguhr G**

*Description.* A fine, greyish white powder with an average particle size of between 10 and 40  $\mu$ m containing about 150g of calcium sulfate, hemihydrate per kg. (The grey colour becomes more pronounced when the powder is triturated with water.)

*Content of calcium sulfate.* Place about 0.25 g, accurately weighed, in a flask with a ground-glass stopper, add 3 ml of hydrochloric acid (~70 g/l) TS and 100 ml of water and shake vigorously for 30 minutes. Filter through a sintered-glass filter and wash the residue. Using the combined filtrate and washings, carry out the assay for calcium by complexometry (The international pharmacopoeia, Vol. 1, page 128). Each ml of disodium edetate (0.05 mol/l) VS is equivalent to 7.26 mg of  $\text{CaSO}_4 \cdot 1/2\text{H}_2\text{O}$  ( $M_r$  145.1).

*pH.* Shake 1 g with 10 ml of carbon-dioxide-free water R for 5 minutes. Measure the pH potentiometrically (The international pharmacopoeia, Vol. 1, page 96); pH should be between 7 and 8.

*Preparation.* Suspend 30g in 60ml of sodium acetate (1.6g/l) TS shaking vigorously for 30 seconds. Carefully coat cleaned plates with a layer 0.25 mm thick using a spreading device. Allow the coated plates to dry in air.

*Separating power.* Apply separately to the adsorbent layer 5  $\mu$ l of 0.10 mg/ml solutions containing respectively lactose R, sucrose R, glucose R, D-fructose R and D-galactose R in pyridine R. Develop the plate using a mixture of 65 volumes of ethyl acetate R, 23 volumes of 2-propanol R and 12 volumes of water. After removing the plate from the chromatographic chamber, dry it in an oven at 105-110°C and allow to cool. Spray the plate with about 10 ml of anisaldehyde TS and heat to 100-105°C for 5-10 minutes. The chromatogram shows five clearly separated spots without tailing.

### **Kieselguhr GF<sub>254</sub>**

*Description.* A fine, greyish white powder with an average particle size of between 10 and 40  $\mu$ m containing about 150 g of calcium sulfate, hemihydrate per kg and a fluorescent indicator with an optimal intensity at 254 nm. (The grey colour becomes more pronounced when the powder is triturated with water.)

*Content of calcium sulfate.* Place about 0.25 g, accurately weighed, in a flask with a ground-glass stopper, add 3 ml of hydrochloric acid (~70 g/l) TS and 100 ml of water and shake vigorously for 30 minutes. Filter through a sintered-glass filter

and wash the residue. Using the combined filtrate and washings, carry out the assay for calcium by complexometry (*The international pharmacopoeia*, Vol. 1, page 128). Each ml of disodium edetate (0.05 mol/l) VS is equivalent to 7.26 mg of  $\text{CaSO}_4 \cdot 1/2\text{H}_2\text{O}$  ( $M_r$  145.1).

*pH*. Shake 1 g with 10 ml of carbon-dioxide-free water R for 5 minutes. Measure the pH potentiometrically (*The international pharmacopoeia*, Vol. 1, page 96); pH is between 7 and 8.

*Preparation*. Suspend 30 g in 60 ml of sodium acetate (1.6 g/l) TS shaking vigorously for 30 seconds. Carefully coat cleaned plates with a layer 0.25 mm thick using a spreading device. Allow the coated plates to dry in air.

*Separating power*. Apply separately to the adsorbent layer 5  $\mu\text{l}$  of 0.10 mg/ml solutions containing respectively lactose R, sucrose R, glucose R, D-fructose R and D-galactose R in pyridine R. Develop the plate using a mixture of 65 volumes of ethyl acetate R, 23 volumes of 2-propanol R and 12 volumes of water. After removing the plate from the chromatographic chamber, dry it in an oven at 105-110°C and allow to cool. Spray the plate with about 10 ml of anisaldehyde TS and heat to 100-105°C for 5-10 minutes. The chromatogram shows five clearly separated spots without tailing.

*Fluorescence*. Prepare a 1.0 mg/ml solution of benzoic acid R in a mixture of 9 volumes of 2-propanol R and 1 volume of formic acid (~1080g/l) TS. Apply to the adsorbent layer at 10 points of application, increasing the quantities of the solution from 1  $\mu\text{l}$  to 10  $\mu\text{l}$ . Develop the chromatogram using a mixture of 9 volumes of 2-propanol R and 1 volume of formic acid R. Allow the solvents to evaporate and examine the chromatogram in ultraviolet light at 254 nm. The benzoic acid appears as dark spots on a fluorescent background in the upper third of the chromatogram for amounts of 2  $\mu\text{g}$  and more.

### **Kieselguhr H**

*Description*. A fine, greyish white powder with an average particle size of between 10 and 40  $\mu\text{m}$ . (The grey colour becomes more pronounced when the powder is triturated with water.)

*pH*. Shake 1 g with 10 ml of carbon-dioxide-free water R for 5 minutes. Measure the pH potentiometrically (*The international pharmacopoeia*, Vol. 1, page 96); pH is between 6.4 and 8.0.

*Preparation*. Suspend 30 g in 60 ml of sodium acetate (1.6 g/l) TS shaking vigorously for 30 seconds. Carefully coat cleaned plates with a layer 0.25 mm thick using a spreading device. Allow the coated plates to dry in air.

*Separating power*. Apply separately to the adsorbent layer 5  $\mu\text{l}$  of 0.10 mg/ml solutions containing respectively lactose R, sucrose R, glucose R, D-fructose R and D-galactose R in pyridine R. Develop the plate using a mixture of 65 volumes of ethyl acetate R, 23 volumes of 2-propanol R and 12 volumes of water. After removing the plate from the chromatographic chamber, dry it in an oven



at 105-110°C and allow to cool. Spray the plate with about 10 ml of anisaldehyde TS and heat to 100-105°C for 5-10 minutes. The chromatogram shows five clearly separated spots without tailing.

### **Silica gel G**

*Description.* A fine, white, homogeneous powder with an average particle size of between 10 and 44 µm containing about 130g of calcium sulfate, hemihydrate per kg.

*Content of calcium sulfate.* Place about 0.25 g, accurately weighed, in a flask with a ground-glass stopper, add 3 ml of hydrochloric acid (~70g/l) TS and 100 ml of water and shake vigorously for 30 minutes. Filter through a sintered-glass filter and wash the residue. Using the combined filtrate and washings, carry out the assay for calcium by complexometry (*The international pharmacopoeia*, Vol. 1, page 128). Each ml of disodium edetate (0.05 mol/l) VS is equivalent to 7.26 mg of CaSO<sub>4</sub>·1/2H<sub>2</sub>O (MW 145.1).

*pH.* Shake 1 g with 10 ml of carbon-dioxide-free water R for 5 minutes. Measure the pH potentiometrically (*The international pharmacopoeia*, Vol. 1, page 96); pH is about 7.

*Preparation.* Suspend 30g in 60 ml of water, shaking vigorously for 30 seconds. Carefully coat the cleaned plates with a layer 0.25 mm thick using a spreading device. Allow the coated plates to dry in air.

*Separating power.* Apply separately to the adsorbent layer 10 µl of 0.10 mg/ml solutions containing respectively indophenol blue R, sudan red G R and dimethyl yellow R in toluene R. Develop the plate with the same solvent over a distance of 10 cm. The chromatogram shows three clearly separated spots, the spot of indophenol blue near the points of application, that of dimethyl yellow in the middle of the chromatogram, and that of sudan red G between the two.

### **Silica gel GF<sub>254</sub>**

*Description.* A fine, white, homogeneous powder with an average particle size of between 10 and 40 µm containing about 130 g of calcium sulfate, hemihydrate per kg and about 150 g of a fluorescent indicator per kg with an optimal intensity at 254 nm.

*Content of calcium sulfate.* Place about 0.25 g, accurately weighed, in a flask with a ground-glass stopper, add 3 ml of hydrochloric acid (~70 g/l) TS and 100 ml of water and shake vigorously for 30 minutes. Filter through a sintered-glass filter and wash the residue. Using the combined filtrate and washings, carry out the assay for calcium by complexometry (*The international pharmacopoeia*, Vol. 1, page 128). Each ml of disodium edetate (0.05 mol/l) VS is equivalent to 7.26 mg of CaSO<sub>4</sub>·1/2H<sub>2</sub>O (M<sub>r</sub> 145.1).

*pH.* Shake 1 g with 10 ml of carbon-dioxide-free water R for 5 minutes. Measure the pH potentiometrically (*The international pharmacopoeia*, Vol. 1, page 96); pH is about 7.

*Preparation.* Suspend 30g in 60 ml of water, shaking vigorously for 30 seconds. Carefully coat the cleaned plates with a layer 0.25 mm thick using a spreading device. Allow the coated plates to dry in air.

*Separating power.* Apply separately to the adsorbent layer 10 µl of 0.10 mg/ml solutions containing respectively indophenol blue R, sudan red G R and dimethyl yellow R in toluene R. Develop the plate with the same solvent over a distance of 10 cm. The chromatogram shows three clearly separated spots, the spot of indophenol blue near the point of application, that of dimethyl yellow in the middle of the chromatogram, and that of sudan red G between the two.

*Fluorescence.* Prepare a 1.0 mg/ml solution of benzoic acid R in a mixture of 9 volumes of 2-propanol R and 1 volume of formic acid (~1080g/l) TS. Apply to the adsorbent layer at 10 points of application, increasing the quantities of the solution from 1 µl to 10 µl. Develop the chromatogram using a mixture of 9 volumes of 2-propanol R and 1 volume of formic acid (~1080 g/l) TS. Allow the solvents to evaporate and examine the chromatogram in ultraviolet light at 254 nm. The benzoic acid appears as dark spots on a fluorescent background in the upper third of the chromatogram for amounts of 2 µg and more.

### **Silica gel H**

*Description.* A fine, white, homogeneous powder with an average particle size of between 10 and 44 µm.

*pH.* Shake 1 g with 10 ml of carbon-dioxide-free water R for 5 minutes. Measure the pH potentiometrically (*The international pharmacopoeia*, Vol. 1, page 96); pH is about 7.

*Preparation.* Suspend 30g in 60 ml of water, shaking vigorously for 30 seconds. Carefully coat the cleaned plates with a layer 0.25 mm thick using a spreading device. Allow the coated plates to dry in air.

*Separating power.* Apply separately to the adsorbent layer 10 µl of 0.10 mg/ml solutions containing respectively indophenol blue R, sudan red G R and dimethyl yellow R in toluene R. Develop the plate with the same solvent over a distance of 10 cm. The chromatogram shows three clearly separated spots, the spot of indophenol blue near the point of application, that of dimethyl yellow in the middle of the chromatogram, and that of sudan red G between the two.

### **Silica gel HF<sub>254</sub>**

*Description.* A fine, white, homogeneous powder with an average particle size of between 10 and 40 µm containing about 150g of a fluorescent indicator per kg with an optimal intensity at 254 nm.

*pH.* Shake 1 g with 10 ml of carbon-dioxide-free water R for 5 minutes. Measure the pH potentiometrically (*The international pharmacopoeia*, Vol. 1, page 96); pH is about 7.

*Preparation.* Suspend 30g in 60 ml of water, shaking vigorously for 30 seconds. Carefully coat the cleaned plates with a layer 0.25 mm thick using a spreading device. Allow the coated plates to dry in air.

*Separating power.* Apply separately to the adsorbent layer 10  $\mu$ l of 0.10 mg/ml solutions containing respectively indophenol blue R, sudan red G R and dimethyl yellow R in toluene R. Develop the plate with the same solvent over a distance of 10 cm. The chromatogram shows three clearly separated spots, the spot of indophenol blue near the point of application, that of dimethyl yellow in the middle of the chromatogram, and that of sudan red G between the two.

*Fluorescence.* Prepare a 1.0 mg/ml solution of benzoic acid R in a mixture of 9 volumes of 2-propanol R and 1 volume of formic acid (~1080g/l) TS. Apply to the adsorbent layer at 10 points of application, increasing the quantities of the solution from 1  $\mu$ l to 10  $\mu$ l. Develop the chromatogram using a mixture of 9 volumes of 2-propanol R and 1 volume of formic acid (~1080g/l) TS. Allow the solvents to evaporate and examine the chromatogram in ultraviolet light at 254 nm. The benzoic acid appears as dark spots on a fluorescent background in the upper third of the chromatogram for amounts of 2  $\mu$ g and more.

#### **Silica gel, HF<sub>254</sub>, silanized**

*Description.* A fine, white, homogeneous powder which, after shaking with water, floats on the surface because of its water-repellent properties. It contains about 150 g of a fluorescent indicator per kg with an optimal intensity at 254 nm.

*Preparation.* Suspend 30 g with 60 ml of a mixture of 2 volumes of water and 1 volume of methanol R shaking vigorously for 2 minutes. Carefully coat the cleaned plates with a layer 0.25 mm thick using a spreading device. Allow the coated plates to dry in air, then dry for 30 minutes in an oven at 100-105°C.

*Separating power.* Prepare a mixture containing 0.1 g of each of methyl laurate R, methyl myristate R, methyl palmitate R and methyl stearate R. Then add 40 ml of a 0.3g/ml decanted solution of potassium hydroxide R in ethanol (~710g/l) TS and heat under reflux on a water-bath for 1 hour. Cool, add 100 ml of water, acidify with hydrochloric acid (~70g/l) TS and extract with three 1-ml volumes of chloroform R. Dry the combined chloroform extracts over anhydrous sodium sulfate R, filter and evaporate to dryness. Dissolve the residue in 50 ml of chloroform R. Apply separately to the adsorbent layer, three 10  $\mu$ l portions of this solution and develop the chromatogram in a mixture of 65 volumes of dioxan R, 25 volumes of water and 10 volumes of glacial acetic acid R. After removing the plate from the chromatographic chamber, heat it in an oven at 120°C for 30 minutes. Allow to cool, spray with a solution containing 35 mg of phosphomolybdic acid R per ml of 2-propanol R and heat at 50°C until the spots become visible. Expose the plate to ammonia vapour until the adsorbent turns white. The chromatogram shows four clearly separated spots.

*Fluorescence.* Prepare a 1.0 mg/ml solution of benzoic acid R in a mixture of 9 volumes of 2-propanol R and 1 volume of formic acid (~1080g/l) TS. Apply to the adsorbent layer at 10 points of application, increasing the quantities of the

solution from 1  $\mu\text{l}$  to 10  $\mu\text{l}$ . Develop the chromatogram using a mixture of 9 volumes of 2-propanol R and 1 volume of formic acid ( $\sim 1080\text{g/l}$ ) TS. Allow the solvents to evaporate and examine the chromatogram in ultraviolet light at 254 nm. The benzoic acid appears as dark spots on a fluorescent background in the upper third of the chromatogram for amounts of 2  $\mu\text{g}$  and more.

## 22. Reagents and solutions

The reagents, test solutions and volumetric solutions mentioned in this publication are described below. Reagents are denoted by the abbreviation R, test solutions by the abbreviation TS, and volumetric solutions by the abbreviation VS. The concentration of the reagent solutions is expressed in g/l, that is, grams of anhydrous substance per litre of water or solvent, as indicated. Where no solvent is indicated, demineralized water should be used. The procedures for the preparation of test solutions that require special attention are given in detail. The designation  $d$  denotes the relative density  $d_{20}^{20}$ , i.e. measured in air at 20°C in relation to water at 20°C. Colour Index (C.I.) numbers are provided for stains.

**Acetic acid, glacial, R.**  $C_2H_4O_2$ ;  $d \sim 1.048$ .

A suitable commercially available reagent.

**Acetic acid (~300 g/l) TS.** A solution of glacial acetic acid R containing about 300g of  $C_2H_4O_2$  per litre (approximately 5 mol/l);  $d \sim 1.037$ .

**Acetic acid (~60g/l) TS.** Acetic acid (~300g/l) TS, diluted to contain about 60g of  $C_2H_4O_2$  per litre (approximately 1 mol/l);  $d \sim 1.008$ .

**Acetone R.**  $C_3H_6O$ .

A suitable commercially available reagent.

**Acetonitrile R.** Methyl cyanide,  $C_2H_3N$ .

*Description.* A clear, colourless liquid.

*Miscibility.* Freely soluble with water.

A suitable commercially available reagent.

**Aflatoxin mixture TS.**

*Procedure.* Prepare a mixed working standard in a mixture of 98 volumes of chloroform R and 2 volumes of acetonitrile R, containing 0.5 µg of each of aflatoxins B<sub>1</sub> and G<sub>1</sub> per ml, and 0.1 µg of each of aflatoxins B<sub>2</sub> and G<sub>2</sub> per ml.

*Note.* Aflatoxins are highly toxic and should be handled with care. National legal requirements should be followed.

Suitable commercially available working standards.

**Agar R.**

A suitable commercially available reagent.

**Aluminium chloride R.**  $AlCl_3 \cdot 6H_2O$ .

A suitable commercially available reagent.

**Aluminium oxide, purified, R.**  $Al_2O_3$ .

A suitable commercially available reagent for column chromatography.

**Amaranth S R.** C.I. 16185; acid red 27;  $C_{20}H_{11}N_2Na_3O_{10}S_3$ .

*Description.* A deep brown or deep reddish brown, fine powder.

A suitable commercially available reagent.

**1,2,4-Aminonaphtholsulfonic acid R.**  $C_{10}H_9NO_4S$ .

*Description.* A white to slightly brownish pink powder.

*Solubility.* Sparingly soluble in water.

A suitable commercially available reagent.

**Aminonaphtholsulfonic acid TS.**

*Procedure.* Add 0.25g of 1,2,4-aminonaphtholsulfonic acid R to 100ml of freshly prepared sodium metabisulfite (150g/l) TS with mechanical stirring. After stirring for 15 minutes, add 0.5 g of anhydrous sodium sulfite R. After stirring for an additional 5 minutes, filter the mixture.

*Storage.* Keep in a brown bottle.

*Note.* This reagent should be prepared freshly every week.

**Ammonia (~260g/l) TS.**  $d \sim 0.894$ .

A suitable commercially available reagent.

**Ammonia (~100g/l) TS.** Ammonia (~260g/l) TS, diluted to contain about 100g of  $NH_3$  per litre (approximately 6 mol/l);  $d$  0.956.

**Ammonium iron(III) citrate, brown, R.** Ferric ammonium citrate, brown; soluble ferric citrate.

Contains about 9% of  $NH_3$ , 16.5-18.5% of Fe, and about 65% of hydrated citric acid.

*Description.* Reddish brown granules, garnet-red transparent scales, or brownish yellow powder; odourless or slight odour of  $NH_3$ . Very deliquescent.

*Solubility.* Very soluble in water; practically insoluble in ethanol (~750g/l) TS.

*Storage.* Store in a well closed container, protected from light.

A suitable commercially available reagent.

**Ammonium molybdate R.**  $(NH_4)_6Mo_7O_{24} \cdot 4H_2O$ .

A suitable commercially available reagent.

**Ammonium molybdate (40g/l) TS.** A solution of ammonium molybdate R containing about 40g of  $(NH_4)_6Mo_7O_{24} \cdot 4H_2O$  per litre.

**Ammonium nitrate R.**  $NH_4NO_3$ .

A suitable commercially available reagent.

**Ammonium oxalate R.**  $C_2H_8N_2O_4 \cdot H_2O$ .

A suitable commercially available reagent.

**Ammonium oxalate (25 g/l) TS.** A solution of ammonium oxalate R containing about 27g of  $C_2H_8N_2O_4$  per litre.

**Ammonium thiocyanate R.**  $CH_4N_2S$ .

A suitable commercially available reagent.

**Ammonium thiocyanate (75 g/l) TS.** A solution of ammonium thiocyanate R containing about 75 g of  $\text{CH}_4\text{N}_2\text{S}$  per litre (approximately 1 mol/l).

**Anisaldehyde R.** 4-Methoxybenzaldehyde;  $\text{C}_8\text{H}_8\text{O}_2$ .

*Description.* A colourless to pale yellow, oily liquid with an aromatic odour.

*Boiling point.* About  $248^\circ\text{C}$ .

*Mass density ( $\rho_{20}$ ).* About 1.125kg/l.

A suitable commercially available reagent.

**Anisaldehyde TS.**

*Procedure.* Mix in the following order: 0.5 ml of anisaldehyde R, 10 ml of glacial acetic acid R, 85 ml of methanol R and 5 ml of sulfuric acid (~1760 g/l) TS.

**Argon R.** Ar. Contains not less than 999.95 ml of Ar per litre.

A suitable commercially available reagent.

**Argon-methane R.**

A suitable commercially available reagent.

**Arsenic, dilute, AsTS.** One millilitre contains 10  $\mu\text{g}$  of arsenic.

*Procedure.* Dilute 1 ml of strong arsenic AsTS with sufficient water to produce 100 ml.

*Note.* Dilute arsenic AsTS must be freshly prepared.

**Arsenic, strong, AsTS.**

*Procedure.* Dissolve 0.132 g of arsenic trioxide R in 6 ml of sodium hydroxide (~80g/l) TS, by gentle heating. Dilute the cooled solution with 20ml of water, and add 50 ml of hydrochloric acid (~250g/l) TS and sufficient water to produce 100 ml.

**Arsenic trioxide R.**  $\text{As}_2\text{O}_3$ .

A suitable commercially available reagent.

**Beads for gel chromatography.**

A suitable commercially available material for gel chromatography.

**Beef extract R.** A residue from beef broth obtained by extracting fresh, sound, lean beef by cooking with water and evaporating the resulting broth at a low temperature, usually under reduced pressure until a thick pasty residue is obtained.

A suitable commercially available reagent.

**Benzoic acid R.**  $\text{C}_7\text{H}_6\text{O}_2$ . Contains not less than 99.8% of  $\text{C}_7\text{H}_6\text{O}_2$ .

*Description.* Colourless, light, feathery crystals or a white, microcrystalline powder; characteristic, faint odour.

*Solubility.* Slightly soluble in water; freely soluble in ethanol (~750g/l) TS, ether R, and chloroform R.

*Methanol-insoluble substances.* Dissolve 20g in 200 ml of methanol R and digest under complete reflux for 30 minutes. Filter through a tared filtering crucible,

wash thoroughly with methanol R, and dry at 105°C; leaves a residue of not more than 1.0 mg.

*Assay.* Dissolve about 0.5 g, accurately weighed, in 15 ml of ethanol (~750g/l) TS, previously neutralized to phenol red/ethanol TS, add 20ml of water and titrate with sodium hydroxide (0.1 mol/l) VS, using phenol red/ethanol TS as indicator. Repeat the operation without the substance being examined and make any necessary correction. Each ml of sodium hydroxide (0.1 mol/l) VS is equivalent to 12.21 mg of C<sub>7</sub>H<sub>6</sub>O<sub>2</sub>.

**Benzympenicillin sodium R.** C<sub>16</sub>H<sub>17</sub>N<sub>2</sub>NaO<sub>4</sub>S. Quality conforms to the monograph in *The international pharmacopoeia*. Vol. 2, p. 51.

**Bile salts R.**

*Description.* A concentrate of beef bile, the principal constituent of which is sodium desoxycholate, determined as cholic acid.

*Solubility.* Soluble in water and in ethanol (~750g/l) TS.

*Acidity.* pH of a 0.02 g/ml solution 5.8-6.2.

A suitable commercially available reagent.

**Brilliant black BN R.** C.I. 28440; C<sub>28</sub>H<sub>17</sub>N<sub>5</sub>Na<sub>4</sub>O<sub>14</sub>S<sub>4</sub>.

*Description.* A bluish violet or greyish black powder or fine crystals.

*Solubility.* Freely soluble in water, practically insoluble in ethanol (~750g/l) TS, acetone R, chloroform R and ether R.

A suitable commercially available reagent.

**Brilliant green R.** Malachite green G; basic green 1; C.I. 42040; C<sub>27</sub>H<sub>34</sub>N<sub>2</sub>O<sub>4</sub>S.

*Description.* Small, glistening golden crystals.

*Solubility.* Soluble in water and ethanol (~750 g/l) TS. A suitable commercially available reagent.

**Bromine R. Br<sub>2</sub>**

A suitable commercially available reagent.

**Bromine AsTS.**

*Procedure.* Dissolve 30g of potassium bromide R in 40 ml of water, add 30g of bromine R and dilute with sufficient water to produce 100 ml. The solution complies with the following test: Evaporate 10 ml nearly to dryness on a water-bath, add 50 ml of water, 10ml of hydrochloric acid (~250g/l) AsTS, and sufficient stannous chloride AsTS to reduce the remaining bromine, and apply the general test for arsenic. The colour of the stain produced is not more intense than that produced from a 1-ml standard stain, showing that the amount of arsenic does not exceed 1 µg/ml.

**Bromocresol purple R.** C<sub>21</sub>H<sub>16</sub>Br<sub>2</sub>O<sub>5</sub>S.

A suitable commercially available reagent.

**Calcium carbonate R1.** CaCO<sub>3</sub>.

A suitable commercially available reagent.



**Calcium carbonate R2.** Calcium carbonate R1 of suitable quality to serve as a primary standard for the standardization of disodium edetate solutions.  
A suitable commercially available reagent.

**Calcon R.** Monosodium salt of 2-hydroxy-1-[(2-hydroxy-1-naphthyl)azo]naphthalene-4-sulfonic acid; C.I. Mordant Black 17, C.I. 15705, Eriochrome Blue Black R, Solochrome Dark Blue;  $C_{20}H_{13}N_2NaO_5S$ .  
A suitable commercially available reagent.

**Calcon carboxylic acid R.** 2-Hydroxy-1-(2-hydroxy-4-sulfo-1-naphthylazo)-3-naphthoic acid;  $C_{21}H_{14}N_2O_7S \cdot 3H_2O$ .

*Description.* A dark-brown powder with a violet tint.

*Solubility.* Practically insoluble in water; slightly soluble in methanol R and in ethanol (~ 750 g/l) TS; freely soluble in solutions of alkali hydroxides.

A suitable commercially available reagent.

**Calcon carboxylic acid indicator mixture R.**

*Procedure.* Mix 0.1 g of calcon carboxylic acid R with 10g of anhydrous sodium sulfate R.

**Calcon indicator mixture R.**

*Procedure.* Mix 0.1 g of calcon R with 10 g of anhydrous sodium sulfate R.

**Cetrimide R.** Contains not less than 96.0% and not more than 101.0% of alkyltrimethylammonium bromide, calculated as  $C_{17}H_{38}BrN$  with reference to the dried substance.

*Description.* A white or almost white, voluminous, free-flowing powder; slight characteristic odour.

*Solubility.* Soluble in two parts of water; freely soluble in ethanol (~750g/l) TS. A suitable commercially available reagent.

**Chinese ink TS.** Indian ink.

A suitable commercially available reagent.

*Note.* Before use, dilute 1 ml of black Chinese ink TS with 2 ml of water; if necessary, further dilute up to 1:10. It must be freshly prepared.

**Chloral hydrate R.**  $C_2H_3Cl_3O_2$ .

*Description.* Colourless, hygroscopic crystals with a sharp odour. Melting temperature. About 55°C.

A suitable commercially available reagent.

**Chloral hydrate TS.**

*Procedure.* Dissolve 50g of chloral hydrate R in 20 ml of water.

**Chloramphenicol R.**  $C_{11}H_{12}Cl_2N_2O_5$ . Quality conforms to the monograph in *The international pharmacopoeia*, Vol. 2, p. 64.

**Chloroform R.**  $CHCl_3$ .

A suitable commercially available reagent.

**Chromic acid TS.**

*Procedure.* Dissolve 84g of chromium trioxide R in 700 ml of water and add slowly, with stirring, 400ml of sulfuric acid (~1760g/l) TS.

**Chromium trioxide R.** CrO<sub>3</sub>.

A suitable commercially available reagent.

**Copper(II) sulfate R.** CuSO<sub>4</sub>·5H<sub>2</sub>O.

A suitable commercially available reagent.

**Crystal violet R.** C<sub>25</sub>H<sub>30</sub>ClN<sub>3</sub>.

A suitable commercially available reagent.

**Cuoxam TS.** Tetramine copper dihydroxide, Schweizer's reagent.

*Procedure.* Dissolve 10g of copper(II) sulfate R in 100 ml of water, and add sufficient sodium hydroxide (~240g/l) TS until alkaline. Filter the precipitate and wash with cold water, previously made sulfate-free. To the moist copper hydroxide add, while stirring, ammonia (~100g/l) TS until dissolved.

*Note.* Cuoxam TS must be freshly prepared.

**Cyclohexane R.** C<sub>6</sub>H<sub>12</sub>.

A suitable commercially available reagent.

**Desmetryn R.** C<sub>9</sub>H<sub>17</sub>N<sub>5</sub>S; 2-methylmercapto-4-methylamino-6-isopropylamino-S-triazine.

A commercially available reagent suitable for use as a reference material.

**Dichloromethane R.** Methylene chloride, CH<sub>2</sub>Cl<sub>2</sub>.

*Description.* A clear colourless, mobile liquid.

*Miscibility.* Freely miscible with ethanol (~750g/l) TS and ether R.

*Boiling range.* Not less than 95% distils between 39 and 41°C.

*Residue on evaporation.* After evaporation on a water-bath and drying at 105°C, leaves not more than 0.5 mg/ml.

A suitable commercially available reagent.

**Dimethyl sulfoxide R.** C<sub>2</sub>H<sub>6</sub>OS.

*Description.* A colourless liquid; odourless or with a slight unpleasant odour.

*Mass density* (ρ<sub>20</sub>). 1.10kg/l.

A suitable commercially available reagent.

**Dimethyl yellow R.** C.I. 11020; 4-dimethylaminoazobenzene; C<sub>14</sub>H<sub>15</sub>N<sub>3</sub>.

*Caution.* Dimethyl yellow R is carcinogenic.

*Description.* Produces a red colour in moderately acidic alcoholic solutions and yellow colour in weakly acidic and alkaline solutions.

*Homogeneity.* Carry out the method for thin-layer chromatography, using silica gel G as the coating substance and dichloromethane R as the mobile phase. Apply 10 µl of a 0.1 mg/ml solution in dichloromethane R. After removing the plate from the chromatographic chamber allow it to dry in air. Only one spot appears on the chromatogram.

A suitable commercially available reagent.

**Dioxan R.** 1,4-Dioxane,  $C_4H_8O_2$ ,

*Caution.* It is dangerous to determine the boiling range or the residue on evaporation before ensuring that the reagent complies with the test for peroxides, described below.

*Description.* A clear, colourless liquid.

*Miscibility.* Miscible with water, ethanol (~750g/l) TS and ether R.

*Boiling range.* Not less than 95% distils between 101 and 105°C.

*Melting temperature.* Solidifies when cooled in ice and does not completely remelt at temperatures below 10°C.

*Residue on evaporation.* Evaporate on a water-bath and dry to than constant weight at 105°C; leaves a residue of not more than 0.1 mg/ml.

*Mass density ( $\rho_{20}$ ).* About 1.031 kg/l.

*Water.* Determined by the Karl Fischer method, not more than 5.0 mg/ml.

*Peroxides.* Add 5 ml to a mixture of 1 g of potassium iodide R dissolved in 10ml of water, 5 ml of hydrochloric acid (~70 g/l) TS, and 2 ml of starch TS, and mix; not more than a faint blue or brown colour is produced.

A suitable commercially available reagent.

**Dipotassium hydrogen phosphate R.**  $K_2HPO_4$ .

A suitable commercially available reagent.

**Disodium edetate R.**  $C_{10}H_{14}N_2Na_2O_8 \cdot 2H_2O$ .

A suitable commercially available reagent.

**Disodium edetate (0.05 mol/l) VS.** Disodium edetate R, dissolved in water to contain 16.81g of  $C_{10}H_{14}N_2Na_2O_8$  in 1000 ml.

*Method of standardization.* Ascertain the exact concentration by an appropriate method. The following method is suitable: transfer about 200mg of calcium carbonate R2, accurately weighed, to a 400-ml beaker, add 10ml of water, and swirl to form a slurry. Cover the beaker with a watch glass, and introduce 2 ml of hydrochloric acid (~70g/l) TS from a pipette inserted between the lip of the beaker and the edge of the watch glass. Swirl the contents of the beaker to dissolve the calcium carbonate. Wash down the sides of the beaker, the outer surface of the pipette, and the watch glass with water, and dilute with water to about 100 ml. While stirring the solution, preferably with a magnetic stirrer, add about 30 ml of the disodium edetate solution from a 50-ml burette. Add 10ml of sodium hydroxide (~80g/l) TS and 0.3g of calcon indicator mixture R or of calcon carboxylic acid indicator mixture R and continue the titration with the disodium edetate solution to a blue end-point. Each 5.005 mg of calcium carbonate is equivalent to 1 ml of disodium edetate (0.05 mol/l) VS.

**Disodium hydrogen phosphate R.**  $Na_2HPO_4 \cdot 12H_2O$ .

A suitable commercially available reagent.

**Ethanol (~750 g/l) TS.**

A suitable commercially available reagent.

**Ethanol (~710 g/l) TS.** A solution of about 950ml of ethanol (~750g/l) TS diluted with water to 1000 ml.

**Ethanol (~375 g/l) TS.** A solution of about 525ml of ethanol (~750g/l) TS diluted with water to 1000 ml.

**Ethanol (~188 g/l) TS.** A solution of about 260ml of ethanol (~750g/l) TS diluted with water to 1000 ml.

**Ethanol (~150 g/l) TS.** A solution of about 210ml of ethanol (~750g/l) TS diluted with water to 1000 ml.

**Ether R. C<sub>4</sub>H<sub>10</sub>O.**

A suitable commercially available reagent.

**Ether/light petroleum TS1.**

*Procedure.* Dilute 60 ml of ether R with sufficient distilled light petroleum R to produce 1000 ml.

**Ether/light petroleum TS2.**

*Procedure.* Dilute 150ml of ether R with sufficient distilled light petroleum R to produce 1000 ml.

**Ether/light petroleum TS3.**

*Procedure.* Dilute 500 ml of ether R with sufficient distilled light petroleum R to produce 1000 ml.

**Ethyl acetate R. C<sub>4</sub>H<sub>8</sub>O<sub>2</sub>.**

A suitable commercially available reagent.

**Fast yellow R. C.I. 13015; E105; C<sub>12</sub>H<sub>9</sub>N<sub>3</sub>Na<sub>2</sub>O<sub>6</sub>S<sub>2</sub>.**

*Description.* An orange-yellow to red powder.

*Solubility.* Freely soluble in water; slightly soluble in ethanol (~750g/l) TS; practically insoluble in ether R and chloroform R.

A suitable commercially available reagent.

**Ferric ammonium sulfate R. FeH<sub>4</sub>NO<sub>8</sub>S<sub>2</sub>·12H<sub>2</sub>O.** This reagent should be free of chlorides.

A suitable commercially available reagent.

**Ferric ammonium sulfate (0.25 mol/l) VS.** Ferric ammonium sulfate R, dissolved in nitric acid (~750 g/l) TS to contain 120.5 g of . FeH<sub>4</sub>NO<sub>8</sub>S<sub>2</sub>·12H<sub>2</sub>O in 1000 ml.

*Procedure.* Dissolve 120.5 g of ferric ammonium sulfate R in a sufficient quantity of nitric acid (~750g/l) TS to produce 1000ml. The reagent should be free of chlorides.

**Ferric chloride R. FeCl<sub>3</sub>·6H<sub>2</sub>O.**

A suitable commercially available reagent.

**Ferric chloride (50 g/l) TS.**

*Procedure.* Dissolve 5 g of ferric chloride R in 100 ml of water.

**Florisil R.**

A suitable commercially available material for column chromatography.

**Formic acid (~1080g/l) TS.** CH<sub>2</sub>O<sub>2</sub>; *d* ~ 1.2.

A suitable commercially available reagent.

**D-Fructose R.** C<sub>6</sub>H<sub>12</sub>O<sub>6</sub>.

*Description.* A white, crystalline powder.

*Melting point.* About 103°C with decomposition.

*Specific optical rotation.* Use a 0.10g/ml solution in water containing 0.05ml of ammonia (~100g/l) TS;  $[\alpha]_{\text{D}}^{20^{\circ}\text{C}}$  = about -92°.

A suitable commercially available reagent.

**D-Galactose R.** C<sub>6</sub>H<sub>12</sub>O<sub>6</sub>.

*Description.* A white, crystalline powder.

*Melting point.* About 164°C.

*Specific optical rotation.* Use a 0.10g/ml solution in water;  $[\alpha]_{\text{D}}^{20^{\circ}\text{C}}$  = about +80°.

A suitable commercially available reagent.

**Glucose R.** Dextrose; C<sub>6</sub>H<sub>12</sub>O<sub>6</sub>. Quality conforms to the monograph in *The international pharmacopoeia*, Vol. 2, p. 135.

**Glucose hydrate R.** Monohydrate of  $\alpha$ -D-glucopyranose, C<sub>6</sub>H<sub>12</sub>O<sub>6</sub>, H<sub>2</sub>O. Contains not less than 99.0% and not more than 101.5% of C<sub>6</sub>H<sub>12</sub>O<sub>6</sub>, calculated with reference to the dried substance.

*Description.* Colourless crystals or a white crystalline or granular powder; odourless.

*Solubility.* Soluble in about 1 part of water and in about 60 parts of ethanol (~750 g/l) TS; more soluble in boiling water and in boiling ethanol (~750g/l) TS.

*Acidity.* Dissolve 5g in 50ml of carbon-dioxide-free water R. Neutralization requires not more than 0.5ml of carbonate-free sodium hydroxide (0.02mol/l) VS, phenolphthalein/ethanol TS being used as indicator.

*Specific optical rotation.* Dissolve 100 mg, previously dried to constant weight, in 1 ml of water, and add a few drops of ammonia (~100g/l) TS;  $[\alpha]_{\text{D}}^{20^{\circ}\text{C}}$  = +52 to +53°.

*Soluble starch or sulfites.* Dissolve 1 g in 10 ml of water and add 1 drop of iodine TS; the liquid is coloured yellow.

*Loss on drying.* Dry to constant weight at 105°C; loses not less than 80mg/g and not more than 100 mg/g.

*Sulfated ash.* Not more than 1.0mg/g.

*Assay.* Dissolve about 0.1 g, accurately weighed, in 50 ml of water, add 30 ml of iodine (0.1 mol/l) VS and 10 ml of sodium carbonate (50g/l) TS, and allow to stand for 20 minutes. Add 15 ml of hydrochloric acid (~70g/l) TS and titrate the excess of iodine with sodium thiosulfate (0.1 mol/l) VS, using starch TS as

indicator. Perform a blank determination and make any necessary corrections. Each ml of iodine (0.1 mol/l) VS is equivalent to 9.008 mg of  $C_6H_{12}O_6$ .

**Glycerol R.** Propane- 1,2,3-triol with small amounts of water,  $C_3H_8O_3$ . Contains not less than 970g/kg of  $C_3H_8O_3$ .

*Description.* A clear, almost colourless, syrupy and hygroscopic liquid; odourless.

*Miscibility.* Miscible with water and ethanol (~750g/l) TS; practically immiscible with ether R and chloroform R.

*Mass density* ( $\rho_{20}$ ). Not less than 1.256kg/l.

*Refractive index* ( $n_D^{20}$ ). Not less than 1.469.

*Acrolein and other reducing substances.* Mix 1 ml with 1 ml of ammonia (~100g/l) TS and heat in a water-bath at 60°C for 5 minutes; the liquid is not coloured yellow. Remove from the water-bath and add 3 drops of silver nitrate (40g/l) TS; the liquid does not become coloured within 5 minutes.

*Sulfated ash.* Not more than 0.5 mg/ml.

A suitable commercially available reagent.

### **Glycerol-ethanol TS.**

*Procedure.* Mix equal volumes of glycerol R, water and ethanol (~750g/l) TS.

**Glycine R.** Aminoacetic acid,  $C_2H_5NO_2$ .

A suitable commercially available reagent.

**Helium R.** He. Contains not less than 999.95 ml of He per litre.

A suitable commercially available reagent.

**Hexane R.** *n*-Hexane,  $C_6H_{14}$ .

*Description.* A colourless, mobile, highly inflammable liquid.

*Boiling range.* Distils completely over a range of 1°C between 67.5 and 69.5°C.

*Mass density* ( $\rho_{20}$ ). 0.658-0.659kg/l.

*Refractive index* ( $n_D^{20}$ ). 1.374-1.375.

A suitable commercially available reagent.

### **Hide powder R.**

A suitable commercially available reference material.

**Hydrochloric acid (~420 g/l) TS.**  $d \sim 1.18$ .

A suitable commercially available reagent.

**Hydrochloric acid (~250 g/l) TS.** A solution of hydrochloric acid (~420g/l) TS in water, containing approximately 250g of HCl per litre;  $d \sim 1.12$ .

**Hydrochloric acid (~250 g/l) AsTS.** Hydrochloric acid (~250g/l) TS that complies with the following tests A and B:

A. Dilute 10ml with sufficient water to produce 50ml, add 5ml of ammonium thiocyanate (75g/l) TS and stir immediately; no colour is produced.

B. To 50 ml add 0.2 ml of bromine AsTS, evaporate on a water-bath until reduced to 16 ml, adding more bromine AsTS if necessary to ensure that an

excess, as indicated by the colour, is present throughout the evaporation. Add 50 ml of water and 5 drops of stannous chloride AsTS and apply the general test for arsenic. The colour of the stain produced is not more intense than that produced from a 0.2-ml standard stain, showing that the amount of arsenic does not exceed 0.05 µg/ml.

**Hydrochloric acid (~250 g/l), stannated, AsTS.**

*Procedure.* Dilute 1 ml of stannous chloride AsTS with sufficient hydrochloric acid (~250g/l) AsTS to produce 100ml.

**Hydrochloric acid (~70g/l) TS.**

*Procedure.* Dilute 260ml of hydrochloric acid (~250g/l) TS with sufficient water to produce 1000ml (approximately 2mol/l);  $d \sim 1.035$ .

**Hydrochloric acid (1 mol/l) VS.** Hydrochloric acid (~250g/l) TS, diluted with water to contain 36.47g of HCl in 1000 ml.

*Method of standardization.* Ascertain the exact concentration of the 1 mol/l solution in the following manner: Dissolve about 1.5g, accurately weighed, of anhydrous sodium carbonate R (previously dried at 270°C for 1 hour) in 50 ml of water and titrate with the hydrochloric acid solution, using methyl orange/ethanol TS as indicator. Each 52.99 mg of anhydrous sodium carbonate R is equivalent to 1 ml of hydrochloric acid (1 mol/l) VS.

**Indian ink** see Chinese ink TS.

**Indophenol blue R.** C.I. 49700;  $C_{18}H_{26}N_2O$ .

*Description.* A violet-black powder.

*Solubility.* Practically insoluble in water; soluble in chloroform R.

*Homogeneity.* Carry out the method for thin-layer chromatography, using silica gel G as the coating substance and dichloromethane R as the mobile phase. Apply 10 µl of a 0.1 mg/ml solution in dichloromethane R and develop. After removing the plate from the chromatographic chamber allow it to dry in air. Only one spot appears on the chromatogram.  
A suitable commercially available reagent.

**Iodine R.**  $I_2$ .

A suitable commercially available reagent.

**Iodine TS.**

*Procedure.* Dissolve 2.6 g of iodine R and 3 g of potassium iodide R in sufficient water to produce 100 ml (approximately 0.1 mol/l).

**Iodine (0.1 mol/l) VS.** Iodine R and potassium iodide R, dissolved in water to contain 25,38g of  $I_2$  and 36.0 g of KI in 1000 ml.

*Method of standardization.* Ascertain the exact concentration of the 0.1 mol/l solution by titrating 25.0 ml with sodium thiosulfate (0.1 mol/l) VS, using starch TS as indicator.

**Iodine (0.02 mol/l) VS.** Iodine R and potassium iodide R, dissolved in water to contain 5.076g of I<sub>2</sub> and 7.2g of KI in 1000 ml.

*Method of standardization.* Ascertain the exact concentration of the solution following the method described under iodine (0.1 mol/l) VS.

**Iodine/ethanol TS.**

*Procedure.* Dissolve 10g of iodine R in sufficient ethanol (~750g/l) TS to produce 1000 ml.

**Iron(III) citrate R.** Ferric citrate, C<sub>6</sub>H<sub>5</sub>FeO<sub>7</sub>, H<sub>2</sub>O. A suitable commercially available reagent.

**Lactic acid R.** C<sub>3</sub>H<sub>6</sub>O<sub>3</sub>. Quality conforms to the monograph in *The international pharmacopoeia*, Vol. 4, p. 115.

**Lactochloral TS.**

*Procedure.* Dissolve 50g of chloral hydrate R in 50g of lactic acid R by gentle heating.

**Lactophenol TS.**

*Procedure.* To a mixture of 20g of lactic acid R and 40g of glycerol R dissolved in 20 ml of water, add 20g of phenol R and mix.

**Lactose R.** C<sub>12</sub>H<sub>22</sub>O<sub>11</sub>.

A suitable commercially available reagent.

**Lead acetate R.** C<sub>4</sub>H<sub>6</sub>O<sub>4</sub>Pb, 3H<sub>2</sub>O.

A suitable commercially available reagent.

**Lead acetate (80 g/l) TS.** A solution of lead acetate R in freshly boiled water containing about 80g/l of . C<sub>4</sub>H<sub>6</sub>O<sub>4</sub>Pb (approximately 0.25mol/l).

**Lithium chloride R.** LiCl.

*Description.* White, deliquescent crystals or granules.

*Solubility.* Freely soluble in water; soluble in acetone R and ethanol (~750g/l) TS.

*Storage.* Store in a tightly closed container.

A suitable commercially available reagent.

**L-Lysine R.** C<sub>6</sub>H<sub>14</sub>N<sub>2</sub>O<sub>2</sub>.

*Description.* Crystalline needles or hexagonal plates.

*Solubility.* Soluble in water; very slightly soluble in ethanol (~750g/l) TS; insoluble in ether R.

*Melting point.* About 213°C with decomposition.

*Specific optical rotation.* Dissolve 0.2g in 10ml of hydrochloric acid (~250g/l) TS;

$[\alpha]_D^{20^\circ} = \text{about } +21.5^\circ$ .

A suitable commercially available reagent.

**Magnesium chloride R.** MgCl<sub>2</sub>, 6H<sub>2</sub>O.

A suitable commercially available reagent.



**Mercuric bromide R.**  $\text{HgBr}_2$ .

A suitable commercially available reagent.

**Mercuric bromide AsTS.**

*Procedure.* Dissolve 5 g of mercuric bromide R in sufficient ethanol (~750 g/l) TS to produce 100 ml.

**Mercuric bromide paper AsR.**

*Procedure.* Use smooth, white filter-paper weighing 65-120 g/m<sup>2</sup>. The thickness of the paper in mm should be approximately equal numerically to the weight expressed as above, divided by 400. Soak pieces of filter-paper, not less than 25 mm in width, in mercuric bromide AsTS, decant the superfluous liquid, suspend the paper over a non-metallic thread and allow it to dry, protected from light.

*Storage.* Store the mercuric bromide paper AsR in stoppered bottles in the dark.

*Note.* Paper that has been exposed to sunlight or to vapours of ammonia must not be used as it produces only a pale stain or no stain at all.

**Mercuric nitrate TS.** Millon's reagent; nitric acid solution of mercury.

*Procedure.* Dissolve 1 ml of mercury R in 9 ml of fuming nitric acid R, keeping the mixture well cooled during the reaction. When the reaction is complete, dilute the solution with an equal volume of water. It should be protected from light and used within two months of preparation.

**Mercuric thiocyanate R.**  $\text{C}_2\text{HgN}_2\text{S}_2$ .

A suitable commercially available reagent.

**Mercuric thiocyanate TS.** A saturated solution of mercuric thiocyanate R in ethanol (~750g/l) TS.

**Mercury R.** Hg.

A suitable commercially available reagent.

**Methane R.**  $\text{CH}_4$ .

A suitable commercially available reagent.

**Methanol R.**  $\text{CH}_4\text{O}$ .

A suitable commercially available reagent.

**Methyl laurate R.**  $\text{C}_{13}\text{H}_{26}\text{O}_2$ .

*Description.* A colourless or pale yellow liquid.

*Mass density* ( $\rho_{20}$ ). About 0.87kg/l.

A suitable commercially available reagent.

**Methyl myristate R.**  $\text{C}_{15}\text{H}_{30}\text{O}_2$ .

*Description.* A colourless or slightly yellow liquid.

*Mass density* ( $\rho_{20}$ ). About 0.87kg/l.

A suitable commercially available reagent.

**Methyl orange R.** Sodium salt of 4'-dimethylaminoazobenzene-4-sulfonic acid,  $C_{14}H_{14}N_3NaO_3S$ .

A suitable commercially available reagent.

**Methyl orange/ethanol TS.**

*Procedure.* Dissolve 0.04g of methyl orange R in sufficient ethanol (~1508/l) TS to produce 100ml.

**Methyl palmitate R.** Methyl hexadecanoate;  $C_{17}H_{34}O_2$ .

*Description.* A colourless, waxy solid.

*Freezing point.* About 27°C.

*Mass density ( $\rho_{20}$ ).* About 0.86kg/l.

A suitable commercially available reagent.

**Methyl stearate R.**  $C_{19}H_{38}O_2$ .

*Description.* A white or pale yellow, crystalline mass.

*Melting point.* About 38°C.

A suitable commercially available reagent.

**1-Naphthol R.**  $C_{10}H_8O$ .

*Description.* Colourless crystals or a white, crystalline powder; odour, characteristic.

*Solubility.* Soluble in 5 parts of ethanol (~750 g/l) TS (may form a slightly opalescent, colourless or almost colourless solution).

*Melting range.* 93-96°C.

*Sulfated ash.* Not more than 0.5 mg/g.

A suitable commercially available reagent.

**1-Naphthol TS.**

*Procedure.* Dissolve 20g of 1-naphthol R in 100ml of ethanol (~750g/l) TS. Protect from light and use within a few days of preparation.

**Neutral red R.** C.I. 50040; C.I. Basic red;  $C_{15}H_{17}ClN_4$ . A suitable commercially available reagent.

**Nitric acid, fuming, R.**  $HNO_3$ .

A suitable commercially available reagent.

**Nitric acid (~1000 g/l) TS.**  $d \sim 1.41$ .

A suitable commercially available reagent.

**Nitric acid (~750 g/l) TS.**

*Procedure.* Dilute 750ml of nitric acid (~1000g/l) TS with sufficient water to produce 1000ml (approximately 12mol/l).

**Nitric acid (~500g/l) TS.**

*Procedure.* Dilute 500ml of nitric acid (~1000 g/l) TS with sufficient water to produce 1000 ml (approximately 8 mol/l).

**Nitric acid (~225 g/l) TS.**

*Procedure.* Dilute 225 ml of nitric acid (~10008/l) TS with sufficient water to produce 1000 ml (approximately 3.5mol/l).

**Nitro-chromic acid TS.**

*Procedure.* Mix equal volumes of nitric acid (~225g/l) TS and chromic acid TS.

**Nitrogen R. N<sub>2</sub>.**

A suitable commercially available reagent.

**Ox bile, dehydrated, R.** Dehydrated, purified fresh bile.

A suitable commercially available reagent.

**Pancreatic digest of casein R.**

A suitable commercially available reagent.

**Pancreatic digest of gelatin R.**

A suitable commercially available reagent.

**Papaic digest of soybean meal R.**

A suitable commercially available reagent.

**Paraffin, liquid, R.**

A suitable commercially available reagent.

**Peptone, dried, R.** A variety of peptones are available from casein, meat, beef or a mixture of these.

A suitable commercially available reagent.

**Perchloric acid (~1170 g/l) TS. *d* ~ 1.67.**

A suitable commercially available reagent.

**Petroleum, light, R.**

A suitable commercially available reagent.

**Phenol R. C<sub>6</sub>H<sub>6</sub>O.**

*Description.* Colourless, or at most faintly pink, cohering or separate acicular crystals, or crystalline masses; characteristic odour. Corrosive, and blanches the skin and mucous membranes.

*Solubility.* Soluble in about 15 parts of water and in about 100 parts of liquid paraffin R; freely soluble in ethanol (~750g/l) TS, ether R and chloroform R.

*Completeness of solution.* 1.0g dissolves completely in 15ml of water at 15°C.

*Congearing temperature.* Not below 40.5°C.

*Residue on evaporation.* Evaporate on a water-bath and dry to constant weight at 105°C; leaves not more than 0.5 mg/g of residue.

A suitable commercially available reagent.

**Phenolphthalein R. C<sub>20</sub>H<sub>14</sub>O<sub>4</sub>.**

A suitable commercially available reagent.

**Phenolphthalein/ethanol TS.**

*Procedure.* Dissolve 1.0g of phenolphthalein R in sufficient ethanol (~750g/l) TS to produce 100 ml.

**Phenol red R.** Phenolsulfonphthalein,  $C_{19}H_{14}O_5S$ . A suitable commercially available reagent.

**Phenol red/ethanol TS.**

*Procedure.* Dissolve 0.05 g of phenol red R in a mixture of 2.85 ml of sodium hydroxide (0.05 mol/l) VS and 5 ml of ethanol (~710g/l) TS. Warm the solution slightly and after cooling dilute with sufficient ethanol (~150 g/l) TS to produce 250 ml.

**Phloroglucinol R.** Benzene- 1,3,5-triol dihydrate;  $C_6H_6O_3 \cdot 2H_2O$ .

*Description.* White or pale cream crystals.

*Melting point.* About 220°C.

A suitable commercially available reagent.

**Phloroglucinol TS.**

*Procedure.* Dissolve 1 g of phloroglucinol R in 100ml of ethanol (~750g/l) TS.

**Phosphate buffer, pH 7.4, TS.**

*Procedure.* Dissolve 6.8 g of potassium dihydrogen phosphate R in 250 ml of water and add 393.4 ml of sodium hydroxide (0.1 mol/l) VS.

**Phosphomolybdic acid R.**  $H_3PO_4 \cdot 12MoO_3 \cdot 24H_2O$ .

A suitable commercially available reagent.

**Phosphorus pentoxide R.**  $P_2O_5$ .

A suitable commercially available reagent.

**Polysorbate 20 R.** Quality conforms to the monograph in *The international pharmacopoeia*, Vol. 4, p. 202.

**Polysorbate 80 R.** Quality conforms to the monograph in *The international pharmacopoeia*, Vol. 4, p. 202.

**Potassium bromide R.** KBr.

A suitable commercially available reagent.

**Potassium chlorate R.**  $KClO_3$ .

A suitable commercially available reagent.

**Potassium dichromate R.**  $K_2Cr_2O_7$ .

A suitable commercially available reagent.

**Potassium dichromate (0.0167 mol/l) VS.** Potassium dichromate R, dissolved in water to contain 4.904g of  $K_2Cr_2O_7$  in 1000 ml.

*Method of standardization.* Ascertain the exact concentration of the 0.0167 mol/l solution in the following manner: Place 25.0ml of the potassium dichromate solution into a glass-stoppered flask. Add 2 g of potassium iodide R, dilute with 200 ml of water, add 5 ml of hydrochloric acid (~420g/l) TS, allow to stand for 10 minutes in a dark place, and titrate the liberated iodine with sodium thiosulfate (0.1 mol/l) VS, adding 3 ml of starch TS as the end-point is approached. Correct for a blank determined using the same quantities of the same reagents.

**Potassium dihydrogen phosphate R.**  $\text{KH}_2\text{PO}_4$ .

A suitable commercially available reagent.

**Potassium hydrogen phthalate R.**  $\text{C}_8\text{H}_5\text{KO}_4$ .

A suitable commercially available reagent.

**Potassium hydroxide R.** KOH.

A suitable commercially available reagent.

**Potassium hydroxide (~110 g/l) TS.** A solution of potassium hydroxide R containing about 112 g of KOH per litre (approximately 2 mol/l).

**Potassium hydroxide (~55 g/l) TS.** A solution of potassium hydroxide R containing about 56g of KOH per litre (approximately 1 mol/l).

**Potassium iodide R.** KI.

A suitable commercially available reagent.

**Potassium iodide AsR.** Potassium iodide R that complies with the following test: Dissolve 10g of potassium iodide R in 25 ml of hydrochloric acid (~250g/l) AsTS and 35 ml of water, add 2 drops of stannous chloride AsTS and apply the general test for arsenic; no visible stain is produced.

**Potassium iodide (80 g/l) TS.** A solution of potassium iodide R containing about 83 g of KI per litre (approximately 0.5 mol/l).

**Potassium sulfate R.**  $\text{K}_2\text{SO}_4$ .

A suitable commercially available reagent.

**Potassium tellurite R.**  $\text{K}_2\text{TeO}_3$  (approx.)

A suitable commercially available reagent.

**Potassium tetrathionate R.**  $\text{K}_2\text{S}_4\text{O}_6$ .

A suitable commercially available reagent.

**Prometryn R.**  $\text{C}_{10}\text{H}_{19}\text{N}_5\text{S}$ .

A commercially available reagent suitable for use as a reference material.

**1-Propanol R.** *n*-Propanol; propan-1-ol,  $\text{C}_3\text{H}_8\text{O}$ .

*Description.* A clear, colourless liquid.

*Miscibility.* Miscible with water and ethanol (~750g/l) TS.

*Boiling range.* Not less than 95% distils between 95 and 98°C.

*Mass density ( $\rho_{20}$ ).* About 0.803 kg/l.

*Residue on evaporation.* Evaporate on a water-bath and dry to constant weight at 105°C; leaves a residue of not more than 0.1 mg/g.

A suitable commercially available reagent.

**2-Propanol R.** Isopropyl alcohol; C<sub>3</sub>H<sub>8</sub>O.

A suitable commercially available reagent.

**Propylene glycol R.** Propane diol, C<sub>3</sub>H<sub>8</sub>O<sub>2</sub>.

A suitable commercially available reagent.

**Pyridine R.** C<sub>5</sub>H<sub>5</sub>N.

A suitable commercially available reagent.

**Quinine hydrochloride R.** C<sub>20</sub>H<sub>24</sub>N<sub>2</sub>O<sub>2</sub>·HCl·2H<sub>2</sub>O. Quality of substance conforms to the monograph in *The international pharmacopoeia*, vol. 2, p. 248.

**Saponin R.**

A suitable commercially available reference material.

**Silica gel R.**

A suitable commercially available material for column chromatography.

**Silica gel, desiccant, R.**

*Description.* An amorphous, partly hydrated SiO<sub>2</sub>, occurring in glassy granules of varying sizes. It is frequently coated with a substance that changes colour when the capacity to absorb water is exhausted. Such coloured products may be regenerated (i.e., may regain their capacity to absorb water) by heating at 110°C until the gel assumes the original colour.

*Loss on drying.* Ignite 2 g, accurately weighed, at 950 ± 50°C to constant weight; the loss is not more than 60 mg/g.

*Water absorption.* Place about 10 g in a tared weighing-bottle, and weigh. Then place the bottle, with the cover removed, for 24 hours in a closed container in which 80% relative humidity is maintained by being in equilibrium with sulfuric acid having a relative density of 1.19. Weigh again; the increase in weight is not less than 310 mg/g.

A suitable commercially available reagent.

**Silver nitrate R.** AgNO<sub>3</sub>.

A suitable commercially available reagent.

**Silver nitrate (40 g/l) TS.** A solution of silver nitrate R containing about 42.5g of AgNO<sub>3</sub> per litre (approximately 0.25 mol/l).

**Simazine R.** C<sub>7</sub>H<sub>12</sub>ClN<sub>5</sub>.

A commercially available reagent suitable for use as a reference material.

**Soda lime R.**

A suitable commercially available reagent.

**Sodium acetate R.**  $C_2H_3NaO_2 \cdot 3H_2O$ .

A suitable commercially available reagent.

**Sodium acetate (1.6 g/l) TS.** A solution of sodium acetate R containing about 1.64 g of  $C_2H_3NaO_2$  per litre (0.02mol/l).

**Sodium carbonate R.**  $Na_2CO_3 \cdot 10H_2O$ .

A suitable commercially available reagent.

**Sodium carbonate, anhydrous, R.**  $Na_2CO_3$ .

A suitable commercially available reagent.

**Sodium carbonate (50 g/l) TS.** A solution of sodium carbonate R containing about 50g of  $Na_2CO_3$  per litre (approximately 0.5 mol/l).

**Sodium carboxymethylcellulose R.**

A suitable commercially available material for chromatography.

**Sodium chloride R.**  $NaCl$ .

A suitable commercially available reagent.

**Sodium chloride (400 g/l) TS.** A solution of sodium chloride R containing about 400g of  $NaCl$  per litre.

**Sodium chloride (100 g/l) TS.** A solution of sodium chloride R containing about 100g of  $NaCl$  per litre.

**Sodium citrate R.**  $C_6H_5Na_3O_7 \cdot 2H_2O$ . Quality of substance conforms to the monograph in *The international pharmacopoeia*, vol. 3, p. 192.

**Sodium citrate (36.5 g/l) TS.** A solution of sodium citrate R containing about 36.5 g of  $C_6H_5Na_3O_7$  per litre.

**Sodium deoxycholate R.**  $C_{23}H_{39}NaO_4$ . Containing not less than 90% of  $C_{23}H_{39}NaO_4$ .

A suitable commercially available reagent.

**Sodium hydroxide R.**  $NaOH$ .

A suitable commercially available reagent.

**Sodium hydroxide (~240 g/l) TS.** A solution of sodium hydroxide R containing about 240g of  $NaOH$  per litre of carbon-dioxide-free water R.

**Sodium hydroxide (~80 g/l) TS.** A solution of sodium hydroxide R containing about 80g of  $NaOH$  per litre (approximately 2mol/l).

**Sodium hydroxide (1 mol/l) VS.** Sodium hydroxide R dissolved in water to produce a solution containing 40.01g of NaOH in 1000 ml.

*Method of standardization.* Ascertain the exact concentration of the 1 mol/l solution in the following manner: Dry about 5g of potassium hydrogen phthalate R at 105°C for 3 hours and weigh accurately. If the potassium hydrogen phthalate is in the form of large crystals, they should be crushed before drying. Dissolve in 75ml of carbon-dioxide-free water R and titrate with the sodium hydroxide solution, using phenolphthalein/ethanol TS as indicator. Each 0.2042g of potassium hydrogen phthalate is equivalent to 1 ml of sodium hydroxide (1 mol/l) VS. Standard solutions of sodium hydroxide should be restandardized frequently.

*Storage.* Solutions of alkali hydroxides absorb carbon dioxide when exposed to air. They should therefore be stored in bottles with suitable non-glass, tightly-fitting stoppers, provided with a tube filled with soda lime R.

**Sodium hydroxide (0.5 mol/l) VS.** Sodium hydroxide R dissolved in water to produce a solution containing 20.00g of NaOH in 1000 ml.

*Method of standardization.* Ascertain the exact concentration of the solution following the method described under sodium hydroxide (1 mol/l) VS.

**Sodium hydroxide (0.1 mol/l) VS.** Sodium hydroxide R dissolved in water to produce a solution containing 4.001 g of NaOH in 1000 ml.

*Method of standardization.* Ascertain the exact concentration of the solution following the method described under sodium hydroxide (1 mol/l) VS.

**Sodium hydroxide (0.05 mol/l) VS.** Sodium hydroxide R, dissolved in water to produce a solution containing 2.000g of NaOH in 1000ml.

*Method of standardization.* Ascertain the exact concentration of the solution following the method described under sodium hydroxide (1 mol/l) VS.

**Sodium hydroxide (0.02 mol/l), carbonate-free, VS.** Sodium hydroxide R, dissolved in water to produce a solution containing 0.8001 g of NaOH in 1000 ml.

*Method of standardization.* Ascertain the exact concentration of the solution following the method described under sodium hydroxide (1 mol/l) VS.

**Sodium hydroxide, methanolic TS.**

*Procedure.* Dissolve 2.5 g of sodium hydroxide R in 10ml of carbon-dioxide-free water R. Add 1 ml of propylene glycol R and dilute to 100 ml with methanol R.

**Sodium hypochlorite TS.** Containing 100-140g of available chlorine per litre.

*Description.* A yellowish liquid; odour of chlorine.

A suitable commercially available reagent.

**Sodium metabisulfite R.**  $\text{Na}_2\text{O}_5\text{S}_2$ .

A suitable commercially available reagent.

**Sodium metabisulfite (150 g/l) TS.** A solution of sodium metabisulfite R containing about 150g of  $\text{Na}_2\text{O}_5\text{S}_2$  per litre.



**Sodium pyruvate R.**  $C_3H_3NaO_2$ .

Description. An almost white to white powder or a crystalline powder.

Solubility. Soluble in water.

A suitable commercially available reagent.

**Sodium sulfate, anhydrous, R.**  $Na_2SO_4$ . A suitable commercially available reagent.

**Sodium sulfate, anhydrous, R.**  $Na_2SO_3$ . A suitable commercially available reagent.

**Sodium thiosulfate R.**  $Na_2S_2O_3 \cdot 5H_2O$ .

A suitable commercially available reagent.

**Sodium thiosulfate (0.1 mol/l) VS.** Sodium thiosulfate R, dissolved in water to produce a solution containing 15.82g of  $Na_2S_2O_3$  in 1000 ml.

*Method of standardization.* Ascertain the exact concentration of the 0.1 mol/l solution in the following manner: transfer 30.0ml of potassium dichromate (0.0167 mol/l) VS to a glass-stoppered flask and dilute with 50ml of water. Add 2g of potassium iodide R and 5ml of hydrochloric acid (~250g/l) TS, stopper and allow to stand for 10 minutes. Dilute with 100 ml of water and titrate the liberated iodine with the sodium thiosulfate solution, using starch TS as indicator. Sodium thiosulfate solutions should be restandardized frequently.

**Stannous chloride R.**  $SnCl_2 \cdot 2H_2O$ .

A suitable commercially available reagent.

**Stannous chloride TS.**

*Procedure.* Dissolve 330g of stannous chloride R in 100ml of hydrochloric acid (~250g/l) TS and sufficient water to produce 1000 ml.

**Stannous chloride AsTS.**

*Procedure.* Prepare from stannous chloride TS by adding an equal volume of hydrochloric acid (~250g/l) TS, boiling down to the original volume, and filtering through a fine-grained filter-paper.

*Test for arsenic.* To 10 ml add 6 ml of water and 10 ml of hydrochloric acid (~250 g/l) AsTS, and distil 16ml. To the distillate add 50ml of water and 2 drops of stannous chloride AsTS and apply the general test for arsenic. The colour of the stain produced is not more intense than that produced from a 1-ml standard stain, showing that the amount of arsenic does not exceed 1 µg/ml.

**Starch R.**

A suitable commercially available reagent.

**Starch, soluble, R.**

A suitable commercially available reagent.

**Starch TS.**

*Procedure.* Mix 0.5 g of starch R or of soluble starch R with 5 ml of water, and add this solution, with constant stirring, to sufficient water to produce about 100ml; boil for a few minutes, cool, and filter.

*Note.* Starch TS should be freshly prepared.

**Sucrose R.**  $C_{12}H_{22}O_{11}$ .

A suitable commercially available reagent.

**Sudan red G R.** 1-(4-Phenylazophenylazo)-2-naphthol; sudan III; solvent red 23; C.I. 26100;  $C_{22}H_{16}N_4O$ .

*Description.* A reddish brown powder.

*Solubility.* Practically insoluble in water; soluble in chloroform R.

A suitable commercially available reagent.

**Sudan red TS.**

*Procedure.* Dissolve 0.5g of sudan red G R in 100 ml of glacial acetic acid R.

**Sulfuric acid (~1760 g/l) TS.**  $d \sim 1.84$ .

A suitable commercially available reagent.

**Sulfuric acid (~1160 g/l) TS.**

*Procedure.* Add 660ml of sulfuric acid (~1760g/l) TS to sufficient water to produce 1000 ml.

**Sulfuric acid (~350 g/l) TS.**

*Procedure.* Add 200ml of sulfuric acid (~1760g/l) TS to sufficient water to produce 1000 ml.

**Sulfuric acid (~300 g/l) TS.**

*Procedure.* Add 171 ml of sulfuric acid (~1760g/l) TS to sufficient water to produce 1000 ml (approximately 3mol/l).

**Sulfuric acid (~37g/l) TS.**

*Procedure.* Add 21.5 ml of sulfuric acid (~1760g/l) TS to sufficient water to produce 1000ml (approximately 0.375mol/l).

**Tetracycline R.**  $C_{22}H_{24}N_2O_8$ .

A suitable commercially available reagent.

**N,N,N',N'-Tetramethyl-p-phenylenediamine dihydrochloride R.**  $C_{10}H_{16}N_2 \cdot 2HCl$ .

*Description.* Whitish grey crystals.

A suitable commercially available reagent.

**Thionine R.** C.I. 52000;  $C_{12}H_{10}ClN_3S$ .

*Description.* Blackish green glistening crystals.

*Solubility.* Freely soluble in hot water.

A suitable commercially available reagent.

**Thionine TS.**

*Procedure.* Dissolve 0.2 g of thionine R in 100 ml of ethanol (~188 g/l) TS.

**Toluene R.** C<sub>7</sub>H<sub>8</sub>.

A suitable commercially available reagent.

**2,2,4-Trimethylpentane R.** C<sub>8</sub>H<sub>18</sub>.

A suitable commercially available reagent.

**Trinitrophenol R.** C<sub>6</sub>H<sub>3</sub>N<sub>3</sub>O<sub>7</sub>.

A suitable commercially available reagent.

**Trinitrophenol, ethanolic, TS.**

*Procedure.* Dissolve 1 g of trinitrophenol R in 100ml of ethanol (~750g/l) TS.

**Tropaeolin O R.** C.I. 14270; E103: resorcin yellow; chrysoin S; sulpho orange; acid orange 6; C<sub>12</sub>H<sub>9</sub>N<sub>2</sub>NaO<sub>5</sub>S.

*Description.* Produces a yellow colour in moderately alkaline solutions and an orange colour in strongly alkaline solutions (pH range 11.0-12.7).

A suitable commercially available reagent.

**Water, carbon-dioxide-free, R.** Water that has been boiled vigorously for a few minutes and protected from the atmosphere during cooling and storage.

**Xylene R.** C<sub>8</sub>H<sub>10</sub>.

A suitable commercially available reagent.

**D-Xylose R.** C<sub>5</sub>H<sub>10</sub>O<sub>5</sub>.

*Description.* A white, crystalline powder.

*Specific optical rotation.* Dissolve 1g in 10 ml of water;  $[\alpha]_D^{20^\circ} = \text{about } +20^\circ$ .

A suitable commercially available reagent.

**Yeast extract, water-soluble, R.**

A suitable commercially available reagent.

**Zinc R, Zn;** granulate, powder, or dust.

A suitable commercially available reagent.

**Zinc, AsR, granulated.** Granulated zinc R that complies with the following tests:

*Limit of arsenic.* Add 10ml of stannated hydrochloric acid (~250g/l) AsTS to 50ml of water, and apply the general test for arsenic; use 10 g of granulated zinc R and allow the reaction to continue for 1 hour; no visible stain is produced.

*Test for sensitivity.* Repeat the test for arsenic with the addition of 0.1 ml of dilute arsenic AsTS; a faint, but distinct yellow stain is produced.

**Zinc acetate R.** C<sub>4</sub>H<sub>6</sub>O<sub>4</sub>Zn,2H<sub>2</sub>O.

A suitable commercially available reagent.

**Zinc acetate/aluminium chloride TS.**

*Procedure.* Dissolve 200g of zinc acetate R and 5g of aluminium chloride R in sufficient water to produce 1000 ml.

**Zinc chloride R.**  $\text{ZnCl}_2$ .

A suitable commercially available reagent.

**Zinc chloride, iodinated, TS.**

*Procedure.* Dissolve 40 g of zinc chloride R and 13 g of potassium iodide R in 21 ml of water. Add 1g of iodine R and shake for 15 minutes. Filter if necessary.

*Storage.* Store protected from light.

## **Acknowledgements**

The World Health Organization acknowledges with thanks the following for their valuable contribution in the preparation of these test procedures:

Professor I. Addae-Mensah, Legon/ Accra, Ghana; Dr S.L. Ali, Eschborn, Germany; Dr H. Blasius, Bonn, Germany; Dr H. Blume, Eschborn, Germany; Dr A. Bonati, Milan, Italy; Dr A.P. Carnat, Clermont-Ferrand, France; Dr H. Cranz, Brussels, Belgium; Dr B. Eberwein, Bonn, Germany; Dr D. Ennet, Berlin, Germany; Dr K. Feiden, Bonn, Germany; Dr L.T. Grady, Rockville, MD, USA; Professor E. Graf, Tübingen, Germany; Professor I. Kapetanidis, Geneva, Switzerland; Dr A. Kaukinen, Helsinki, Finland; Professor L. Kraus, Hamburg, Germany; Professor J. Lemli, Leuven, Belgium; Dr N. Linnenbrink, Nyon, Switzerland; Dr J.J. Liptak, Budapest, Hungary; Professor Lou Zhi-Cen, Beijing, China; Dr A.I. Miroshnikov, Moscow, Russian Federation; Dr Ng Tju Lik, Singapore; Professor S. Philianos, Athens, Greece; Professor J.D. Phillipson, London, England; Ms M.L. Rabouhans, London, England; Mr D.J. Roguet, Geneva, Switzerland; Mr F. Sauer, Brussels, Belgium; Professor H. Schilcher, Berlin, Germany; Professor S. Shibata, Tokyo, Japan; Dr B. Steinhoff, Bonn, Germany; Mr K. Uchida, Tokyo, Japan; Professor C.O.N. Wambebe, Abuja, Nigeria; Dr B. Warren, Woden, Australia; Mr D.A. Wilson, Edinburgh, Scotland; Dr Yang Zhong-Yuan, Wuhan, China; Dr J.H. Zwaving, Groningen, Netherlands.

Thanks are also due to the European Pharmacopoeia Commission and the German Pharmaceutical Codex Commission for providing valuable background material.

## References

1. Quality control methods. In: *Remington: the science and practice of pharmacy*, 19th ed. Easton, PA, MACK, 1995: 118-119.
2. Lachman L et al. Quality control charts. In: *The theory and practice of industrial pharmacy*. Philadelphia, Lea & Febiger, 1986: 817-824.
3. *WHO Expert Committee on Specifications for Pharmaceutical Preparations: thirty-first report*. Geneva, World Health Organization, 1990 (WHO Technical Report Series, No. 790) p. 47.
4. Good manufacturing practices: guidelines on the validation of manufacturing processes. In: *WHO Expert Committee on Specifications for Pharmaceutical Preparations. Thirty-fourth report*. Geneva, World Health Organization, 1996 (WHO Technical Report Series, No. 863): 80-96.
5. *The international pharmacopoeia*, 3rd ed. Geneva, World Health Organization. Vol. 1: *General methods of analysis*, 1979. Vol. 2: *Quality specifications*, 1981. Vol. 3: *Quality specifications*, 1988; Vol. 4: *Tests, methods and general requirements. Quality specifications for pharmaceutical substances, excipients, and dosage forms*, 1994.
6. Lowe DA. *Guide to international recommendations on names and symbols for quantities and on units of measurement*. Geneva, World Health Organization, 1975.
7. *The SI for the health professions*. Geneva, World Health Organization, 1977.
8. *WHO Expert Committee on Specifications for Pharmaceutical Preparations. Thirty-first report*. Geneva, World Health Organization, 1990 (WHO Technical Report Series, No. 790) Annex 2, pp. 34-47.
9. Codex Alimentarius Commission. *Guide. Codex maximum limits for pesticide residues, Part 2, April 1992*. Rome, Food and Agriculture Organization of the United Nations, 1992 (unpublished FAO document CX/PR2-1992; available in hard copy and electronic format from FAO).
10. *Public health impact of pesticides used in agriculture*. Geneva, World Health Organization, 1990.
11. *Official herbicide recommendations for vegetable crops, herbs and medicinal plants*. The Hague, International Society for Horticultural Science, 1981.
12. International Consultative Group on Food Irradiation. *Consultation on microbiological criteria for foods to be further processed including by irradiation*. Geneva, World Health Organization, 1989: 21 (unpublished WHO document WHO/ EHE/FOS/89.5; available on request from Office of Global and Integrated Environmental Health, World Health Organization, 1211 Geneva 27, Switzerland).
13. *Facts about low-level radiation*. Vienna, International Atomic Energy Agency, 1986.
14. *Derived intervention levels for radionuclides in food. Guidelines for application after widespread radioactive contamination resulting from a major radiation accident*. Geneva, World Health Organization, 1988.

## Bibliography

### National and regional pharmacopoeias

*African Pharmacopoeia*. Lagos, OAU/STRC Publications Division, Vol. 1, 1985; Vol. 2, 1986.

*Arzneibuch der deutschen demokratischen Republik*, AB-DDR 85, 1985, AB-DDR 87, 1987 [disestablished].

*British Pharmacopoeia*. London, Her Majesty's Stationery Office, 1993; add. 1994, 1995, 1996, 1997.

*Deutsches Arzneibuch*. Stuttgart, Deutscher Apotheker Verlag, 1996.

*Egyptian Pharmacopoeia*. Cairo, General Organization for Government Printing, 1984.

*European Pharmacopoeia*, 3rd ed. Strasbourg, Council of Europe, 1997 (Suppl. 1998).

*Farmacopea Ufficiale della Repubblica Italiana*, IX. Rome, Ministry of Health, 1985; suppl. 1988, 1991, 1994, 1996.

*Osterreichisches Arzneibuch*. Vienna, Verlag der Osterreichischen Staatsdruckerei, 1990; add. 1, 1990; add. 2, 1991.

*Pharmacopoeia Francaise*, X. Paris, Adrappharm, 1982-1996.

*Pharmacopoea Helvetica*, VIII. Bern, Departement federal de l'Interieur, 1997.

*Pharmacopoea Hungarica*, VII. Budapest, Medicina Konyvkiado, 1986.

*Pharmacopoeia of India*, III. Delhi, Controller of Publications, 1996.

*Pharmacopoeia of the People's Republic of China*. Beijing, Beijing Huayi Biotechnology Co. Ltd, 1985, 1990.

*State Pharmacopoeia of the Union of Soviet Socialist Republics*, XI, Vols. 1 & 2. Moscow, Medicina, 1987, 1990.

*The Pharmacopoeia of Japan*, XIII. Tokyo, Society of Japanese Pharmacopoeia, 1996.

*The United States Pharmacopoeia*, XXIII; *The National Formulary*, XVIII. Rockville, MD, United States Pharmacopoeial Convention, 1995 (Suppl. 1-3, 1995; Suppl. 4 & 5, 1996; Suppl. 6 & 7, 1997).

### Other publications

*International Nonproprietary Names (INN) for pharmaceutical substances. Lists 1-73 of Proposed INN and lists 1-35 of Recommended INN. Cumulative list no. 9*. Geneva, World Health Organization, 1996.

Codex Alimentarius Commission. *Twentieth Session, Geneva, 28 June-7 July 1993*. Rome, Food and Agriculture Organization of the United Nations, 1993 (Alinorm 93/40).

*Guidelines for predicting dietary intake of pesticide residues*, 2nd ed. Geneva, World Health Organization, 1997 (unpublished document WHO/FSF/FOS/97.7;

available from Programme of Food Safety and Food Aid, World Health Organization, 1211 Geneva 27, Switzerland).

*Manuals of food quality control. 2. Additives, contaminants, techniques.* Rome, Food and Agriculture Organization of the United Nations, 1980 (FAO Food and Nutrition Paper 14/2).

*Deutscher Arzneimittel-Codex.* Stuttgart, Deutscher Apotheker Verlag, 1986.

Schilcher H, Peters H, Wank H. Pestizide and Schwermetalle in Arzneipflanzen and Arzneipflanz Zubereitungen. [Pesticides and heavy metals in medicinal plants and medicinal plant preparations.] *Die pharmazeutische Industrie*, 1987, 49: 203-211.



SELECTED WHO PUBLICATIONS OF RELATED INTEREST

Prices in Swiss francs\*

Research guidelines for evaluating the safety and efficacy of herbal medicines  
WHO Regional Office for the Western Pacific 1993 (v + 86 pages) 7.50

Basic tests for drugs: pharmaceutical substances, medicinal plant materials  
and dosage forms 1998 (iii + 91 pages) 26.-

Basic tests for pharmaceutical dosage forms 1991 (v + 129 pages) 24.-

Basic tests for pharmaceutical substances 1986 (205 pages) 34.-

The international pharmacopoeia, third edition Volume I : general methods  
of analysis. 1979 (223 pages) 24.-Volume 2: quality specifications. 1981 (342  
pages) 36.-Volume 3: quality specifications. 1988 (407 pages) 64.-

Volume 4: tests, methods, and general requirements; quality specifications for  
pharmaceutical substances, excipients and dosage forms. 1994 (358 pages)  
85.-

Medicinal plants in China WHO Regional Publications, Western Pacific Series,  
No. 2 1989 (327 pages, 151 colour plates) 50.-

Medicinal plants in Viet Nam WHO Regional Publications, Western Pacific  
Series, No. 3 1990 (410 pages, 200 colour plates) 45.-

Quality assurance of pharmaceuticals: a compendium of guidelines and  
related materials, Vol. 1 1997 (vi + 238 pages) 50.-

WHO Expert Committee on Specifications for Pharmaceutical Preparations  
Thirty-fourth report WHO Technical Report Series, No. 863 1996 (vi + 194  
pages) 35.-

Further information on these and other WHO publications can be obtained  
from Marketing and Dissemination, World Health Organization, 1211 Geneva  
27, Switzerland

\*Prices in developing countries are 70% of those listed here.

Medicinal plants and their products are used worldwide as home remedies, over-the-counter preparations and raw materials for the pharmaceutical industry. They now account for a substantial proportion of the global drug market, and increasing attention is therefore being paid to assurance of their quality, safety and efficacy.

This book has been prepared in response to the need for international harmonization in quality control testing of medicinal plant materials.

It provides step-by-step, descriptions of recommended test methods for identity, purity and content, together with a detailed list of the necessary reagents and solutions. The tests have been selected to fulfil the needs of quality control laboratories and to provide a basis for the development of national standards.

As a practical manual presenting widely applicable methods, the book will be a useful tool for national drug regulatory authorities, the pharmaceutical industry and pharmacists working with medicinal plant materials throughout the world.

Price: Sw. fr. 35.

-Price in developing countries: Sw. fr. 24.50

ISBN 92 4 154510 0